

PHYSICS

Chapter 13: Oscillations

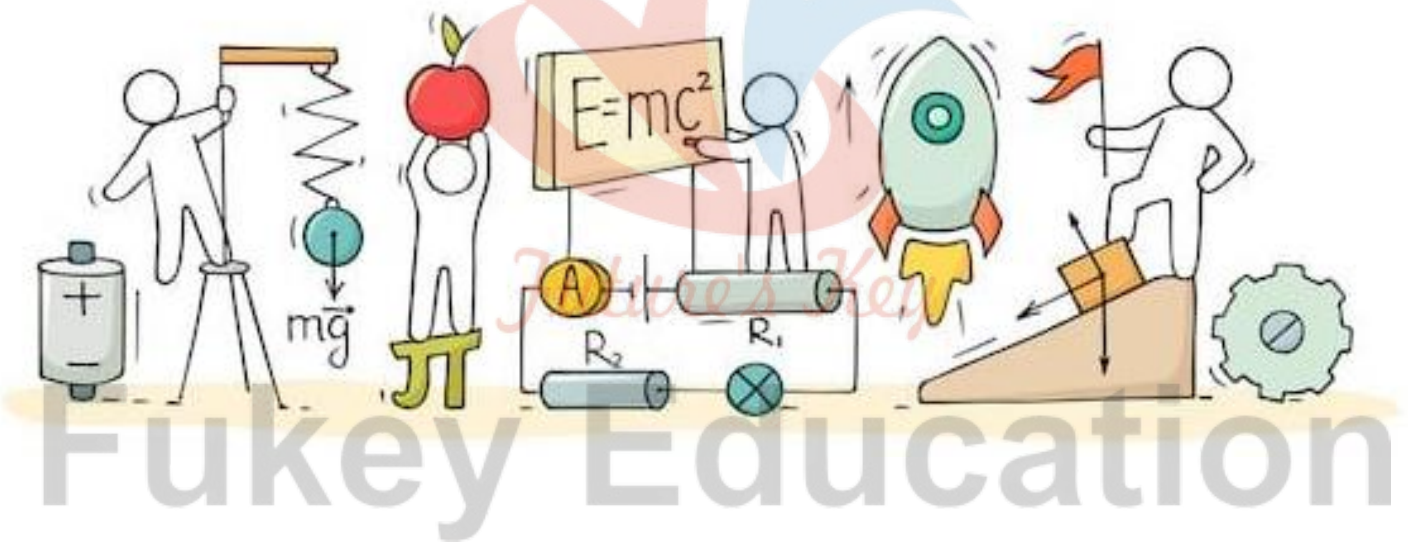

Oscillations

Introduction

In this chapter we will learn about oscillatory motion or oscillations. Any motion which repeats itself at regular intervals of time is known as periodic motion. If a body moves back and forth repeatedly about its mean position, then it is said to be in oscillatory motion.

For example: The to and fro movement of pendulum, jumping on a trampoline, a child swinging on a swing.

Oscillations can be defined as Periodic to and fro motion which repeat itself at regular intervals of time.



To and from motion of pendulum



Child on a swing



Kids jumping on the trampoline

Oscillatory Motion and Periodic Motion

Website - www.fukeyeducation.com, Email :- fukeyeducation@gmail.com

(1)

Periodic motion is defined as the motion that repeats itself after fixed intervals of time. This fixed interval of time is known as time period of the periodic motion. Examples of periodic motion are motion of hands of the clock, motion of planets around the sun etc.

Oscillatory motion is defined as the to and from motion of the body about its fixed position. Oscillatory motion is a type of periodic motion. Examples of oscillatory motion are vibrating strings, swinging of the swing etc.

Oscillatory Motion

Oscillatory motion is defined as the to and from motion of an object from its mean position. The ideal condition is that the object can be in oscillatory motion forever in the absence of friction but in the real world, this is not possible and the object has to settle into equilibrium.

To describe mechanical oscillation, the term vibration is used which is found in a swinging pendulum. Likewise, the beating of the human heart is an example of oscillation in dynamic systems.

Examples of Oscillatory Motion

Following are the examples of oscillatory motion:

Oscillation of simple pendulum

Vibrating strings of musical instruments is a mechanical example of oscillatory motion

Movement of spring

Alternating current is an electrical example of oscillatory motion

Series of oscillations are seen in cosmological model

Simple Harmonic Motion

Simple harmonic motion (SHM) is a type of oscillatory motion which is defined for the particle moving along a straight line with an acceleration which is moving towards a fixed point on the line such that the magnitude is proportional to the distance from the fixed point.

For any simple mechanical harmonic system (system of the weight hung by the spring to the wall) that is displaced from its equilibrium position, a restoring force which obeys the Hooke's law is required to restore the system back to equilibrium. Following is the mathematical representation of restoring force:

$$F = -kx$$

Where,

F is the restoring elastic force exerted by the spring (N)

k is the spring constant (Nm^{-1})

x is the displacement from equilibrium position (m)

Periodic Motion

We can classify the motion of various bodies on the basis of the way they move. For example, a car moving on a straight road is said to have linear motion. Similarly, the motion of the earth around the sun is circular motion. In this session, we shall be discussing periodic motion along with its formula.

A motion that repeats itself after equal intervals of time is known as periodic motion.

Examples of periodic motion: a tuning fork or motion of a pendulum if you analyze the motion you will find that the pendulum passes through the mean position only after a definite interval of time. We can also classify the above motion to be oscillatory. An oscillatory is a motion in which the body moves to and from about a fixed position. So an oscillatory motion can be periodic but it is not necessary.

So taking an example of a wave motion we will see some parameters related to periodic motion. Let's take the following figure:

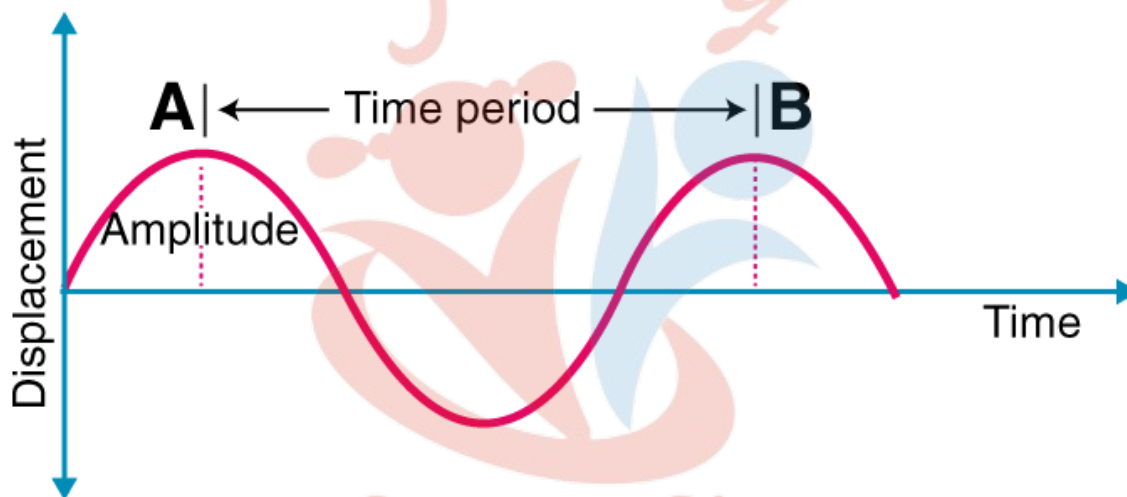

Periodic Motion Formula

Time Period (T): It is the time taken by the motion to repeat itself. So the unit of a time period is seconds.

Frequency (f): It is defined as a number of times the motion is repeated in one second. The unit of frequency is Hz (Hertz). Frequency is related to Time period as:

$$f = \frac{1}{T}$$

Frequency, Time Period and Angular Frequency

As we know, many forms of energy like light and sound travel in waves. A wave is defined through various characteristics like frequency, amplitude and speed. In wave mechanics, any given wave enfolds parameters like – frequency, time period, wavelength, amplitude etc. This article lets us understand and learn in detail about frequency, time period, and angular frequency.

Parameters of a Wave

Frequency definition states that it is the number of complete cycles of waves passing a point in

unit time. The time period is the time taken by a complete cycle of the wave to pass a point. Angular frequency is angular displacement of any element of the wave per unit of time.

Consider the graph shown below. It represents the displacement y of any element for a harmonic wave along a string moving in the positive x -direction with respect to time. Here, the string element moves up and down in simple harmonic motion.

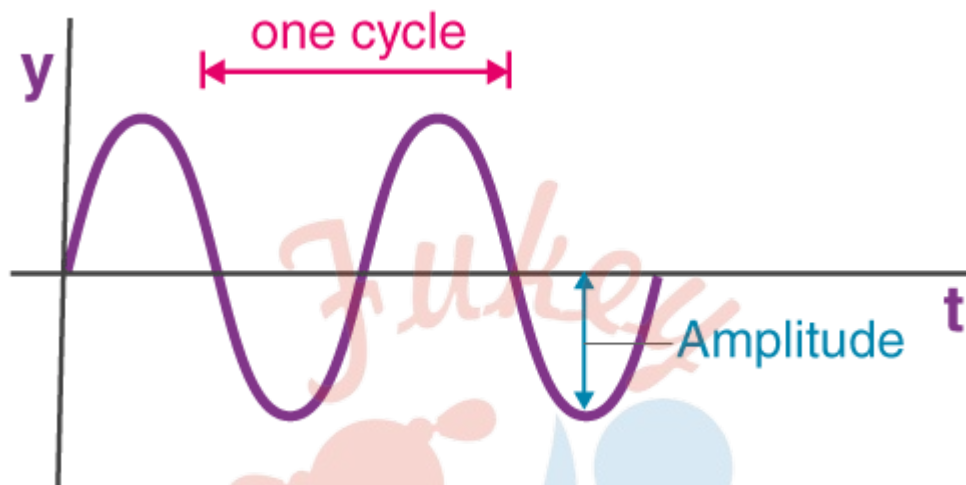

The relation describing the displacement of the element with respect to time is given as:

$y(0,t) = a \sin(-\omega t)$, here we have considered the inception of wave from $x=0$

$y(0,t) = -a \sin(\omega t)$

As we know, sinusoidal or harmonic motion is periodic in nature, i.e. the nature of the graph of an element of the wave repeats itself at a fixed duration. To mark the duration of periodicity following terms are introduced for sinusoidal waves.

Time Period

As shown above, the particles move about the mean equilibrium or mean position with time in a sinusoidal wave motion. The particles rise until they reach the highest point, the crest, and then continue to fall until they reach the lowest point, the trough. The cycle repeats itself in a uniform pattern. The time period of oscillation of a wave is defined as the time taken by any string element to complete one such oscillation. For a sine wave represented by the equation:

$y(0,t) = -a \sin(\omega t)$

The time period formula is given as:

$$T = \frac{2\pi}{\omega}$$

Frequency

We define the frequency of a sinusoidal wave as the number of complete oscillations made by any wave element per unit of time. By the definition of frequency, we can understand that if a body is in periodic motion, it has undergone one cycle after passing through a series of events or positions and returning to its original state. Thus, frequency is a parameter that describes the

rate of oscillation and vibration.

The equation gives the relation between the frequency and the period:

The relation between the frequency and the period is given by the equation:

$$f = 1/T$$

For a sinusoidal wave represented by the equation:

$$y(0,t) = -a \sin(\omega t)$$

The formula of the frequency with the SI unit is given as:

Formula

$$f = \frac{1}{T} = \frac{\omega}{2\pi}$$

SI unit

Hertz

Angular Frequency

For a sinusoidal wave, the angular frequency refers to the angular displacement of any element of the wave per unit of time or the rate of change of the phase of the waveform. It is represented by ω . Angular frequency formula and SI unit are given as:

Formula

$$\omega = \frac{2\pi}{T} = 2\pi f$$

SI unit

rads⁻¹

Where,

ω = angular frequency of the wave.

T = time period of the wave.

f = ordinary frequency of the wave.

Displacement as a function of time and Periodic function

To understand this idea of displacement as a function of time, we will have to derive an expression for displacement, assume a body traveling at an initial velocity of v_1 at the time t_1 and then the body accelerates at a constant acceleration of 'a' for some time and a final velocity of v_2 at the time t_2 , keeping these things in assumption let's derive the following.



Let's write displacement as

$$d = V_{average} * \Delta t$$

Where Δt is the change in time, assuming that the object is under constant acceleration.

$$d = \left(\frac{V_1 + V_2}{2} \right) * \Delta t$$

Where V_2 and V_1 are final and initial velocities respectively, let's rewrite final velocity in terms of initial velocity for the sake of simplicity.

$$d = \left(\frac{V_1 + (V_1 + a * \Delta t)}{2} \right) * \Delta t$$

Where a is the constant acceleration the body is moving at, now if we rewrite the above as,

$$d = \left(\frac{2 * V_1}{2} + \frac{a * \Delta t}{2} \right) * \Delta t$$

The above expression is one of the most fundamental expressions in kinematics, it is also sometimes given as

$$d = V_i t + \frac{1}{2} a t^2$$

Where V_i is the initial velocity, and t is actually the change in time, all the quantities in this derivation, like Velocity, displacement and acceleration, are vector quantities.

Velocity of a particle executing Simple Harmonic Motion

Velocity in SHM is given by $v = dx/dt$,

$$x = A \sin(\omega t + \phi)$$

$$v = \frac{d}{dt} A \sin(\omega t + \phi) = \omega A \cos(\omega t + \phi)$$

$$v = A \omega \sqrt{1 - \sin^2 \omega t}$$

Since, $x = A \sin \omega t$

$$\frac{x^2}{A^2} = \sin^2 \omega t$$

$$\Rightarrow v = A \omega \sqrt{1 - \frac{x^2}{A^2}}$$

$$\Rightarrow v = \omega \sqrt{A^2 - x^2}$$

On squaring both sides

$$\Rightarrow v^2 = \omega^2 (A^2 - x^2)$$

$$\Rightarrow \frac{v^2}{\omega^2} = (A^2 - x^2)$$

$$\Rightarrow \frac{v^2}{\omega^2 A^2} = \left(1 - \frac{x^2}{A^2} \right)$$

$$\Rightarrow \frac{v^2}{A^2} + \frac{v^2}{A^2 \omega^2} = 1$$

this is an equation of an ellipse.

The curve between displacement and velocity of a particle executing the simple harmonic motion is an ellipse.

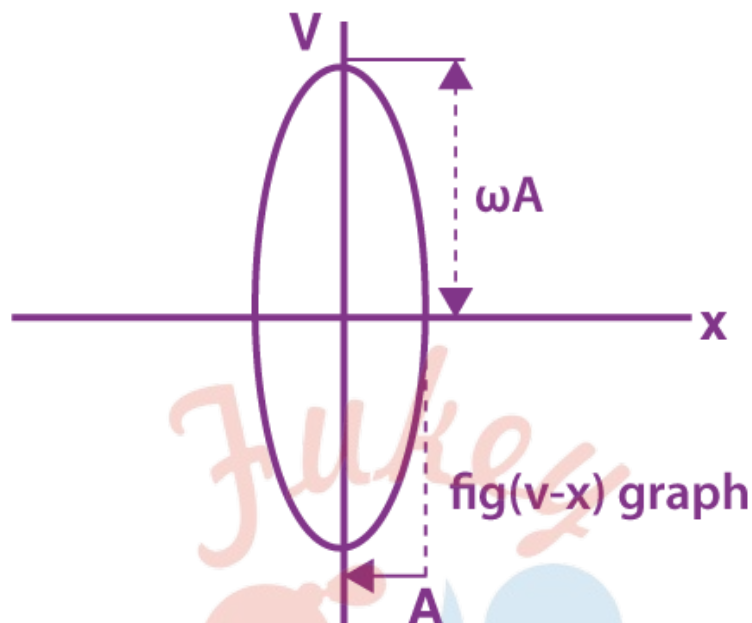

When $\omega = 1$, then the curve between v and x will be circular.

Acceleration in SHM

$$\vec{a} = \frac{dv}{dt} = \frac{d}{dt} (A\omega \cos \omega t + \phi)$$

$$\Rightarrow \vec{a} = -\omega^2 A \sin(\omega t + \phi)$$

$$\Rightarrow |a| = -\omega^2 x$$

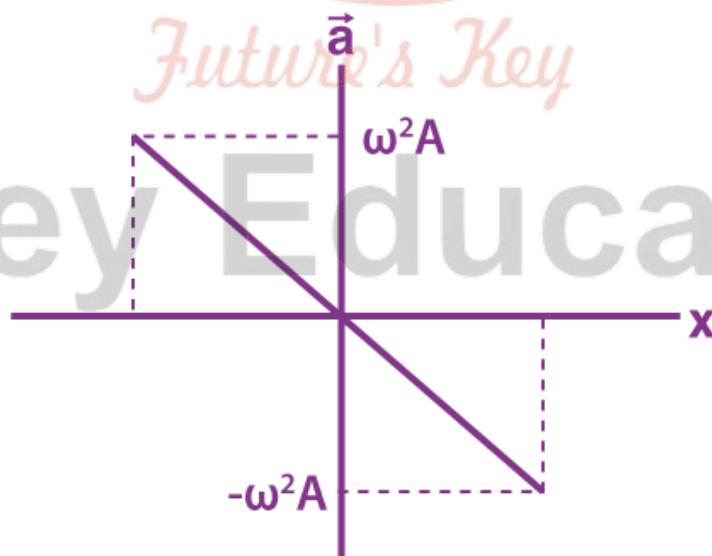

fig. $\vec{a} - \vec{x}$ graph

Hence the expression for displacement, velocity and acceleration in linear simple harmonic motion are

$$x = A \sin (\omega t + \Phi)$$

$$v = A\omega \cos (\omega t + \phi) = \omega \sqrt{A^2 - x^2}$$

and

$$a = -A\omega^2 \sin (\omega t + \phi) = -\omega^2 x$$

Energy in Simple Harmonic Motion (SHM)

The system that executes SHM is called the harmonic oscillator.

Consider a particle of mass m , executing linear simple harmonic motion of angular frequency (ω) and amplitude (A),

the displacement (\vec{x}), velocity (\vec{v}) and acceleration (\vec{a}) at any time t are given by

$$x = A \sin (\omega t + \Phi)$$

$$v = A\omega \cos (\omega t + \phi) = \omega \sqrt{A^2 - x^2}$$

$$a = -\omega^2 A \sin (\omega t + \phi) = -\omega^2 x$$

The restoring force (\vec{F}) acting on the particle is given by

$$F = -kx, \text{ where } k = m\omega^2.$$

Kinetic Energy of a Particle in SHM

$$= \frac{1}{2}mv^2 \text{ [Since, } v^2 = A^2\omega^2\cos^2(\omega t + \phi)\text{]}$$

$$= \frac{1}{2}m\omega^2 A^2\cos^2(\omega t + \phi)$$

$$= \frac{1}{2}m\omega^2 (A^2 - x^2)$$

Therefore, the Kinetic Energy

$$= \frac{1}{2}m\omega^2 A^2\cos^2(\omega t + \phi) = \frac{1}{2}m\omega^2 (A^2 - x^2)$$

Potential Energy of SHM

The total work done by the restoring force in displacing the particle from ($x = 0$) (mean position) to $x = x$:

When the particle has been displaced from x to $x + dx$, the work done by restoring force is $dw = F dx = -kx dx$

$$w = \int dw = \int_0^x -kx dx = \frac{-kx^2}{2}$$

$$= -\frac{m\omega^2 x^2}{2}$$

$$[k = m\omega^2]$$

$$= -\frac{m\omega^2}{2} A^2 \sin^2 (\omega t + \phi)$$

Potential Energy = -(work done by restoring force)

$$= \frac{m\omega^2 x^2}{2} = \frac{m\omega^2 A^2}{2} \sin^2 (\omega t + \phi)$$

Total Mechanical Energy of the Particle Executing SHM

$$E = KE + PE$$

$$E = \frac{1}{2}m\omega^2 (A^2 - x^2) + \frac{1}{2}m\omega^2 x^2$$

$$E = \frac{1}{2}m\omega^2 A^2$$

Hence, the particle's total energy in SHM is constant, independent of the instantaneous displacement.

⇒ Relationship between Kinetic Energy, Potential Energy and time in Simple Harmonic Motion at $t = 0$, when $x = \pm A$.

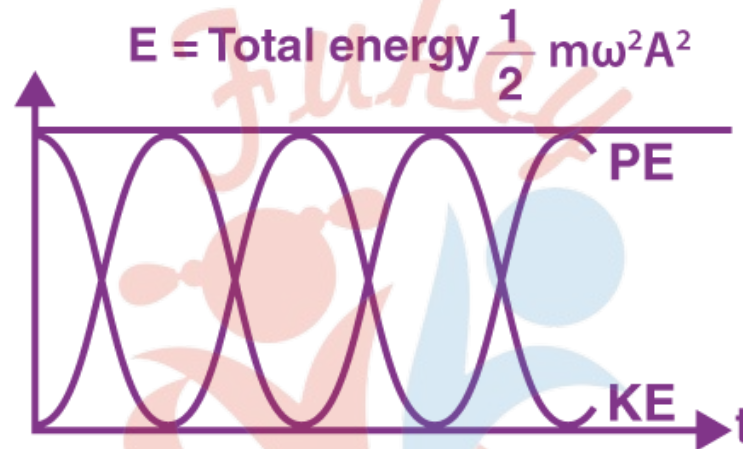
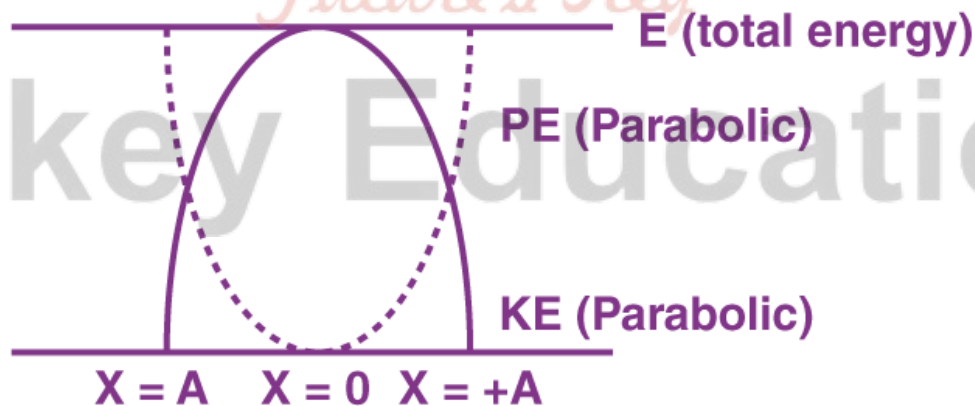

fig. (PE-KE-t) graph

⇒ Variation of Kinetic Energy and Potential Energy in Simple Harmonic Motion with displacement:



Simple Pendulum Definition

A simple pendulum is a mechanical arrangement that demonstrates periodic motion. The simple pendulum comprises a small bob of mass 'm' suspended by a thin string secured to a platform at its upper end of length L.

The simple pendulum is a mechanical system that sways or moves in an oscillatory motion. This motion occurs in a vertical plane and is mainly driven by the gravitational force. Interestingly, the bob that is suspended at the end of a thread very light somewhat we can say it is even massless. The period of a simple pendulum can be made extended by increasing the length string while taking the measurements from the point of suspension to the middle of the bob. However, it should be noted that if the mass of the bob is changed it will the period remains unchanged. Period is influenced mainly by the position of the pendulum in relation to Earth as the strength of gravitational field is not uniform everywhere.

Meanwhile, pendulums are a common system whose usage is seen in various instances. Some are used in clocks to keep track of the time while some are just used for fun in case of a child's swing. In some cases, it is used in an unconventional manner such as a sinker on a fishing line. In any case, we will explore and learn more about the simple pendulum on this page. We will discover the conditions under which it performs simple harmonic motion as well as derive an interesting expression for its period.

Important Terms

The oscillatory motion of a simple pendulum: Oscillatory motion is defined as the to and fro motion of the pendulum in a periodic fashion and the centre point of oscillation known as equilibrium position.

The time period of a simple pendulum: It is defined as the time taken by the pendulum to finish one full oscillation and is denoted by "T".

The amplitude of simple pendulum: It is defined as the distance travelled by the pendulum from the equilibrium position to one side.

Length of a simple pendulum: It is defined as the distance between the point of suspension to the centre of the bob and is denoted by "l".

Spring Mass System Arrangements

Spring mass systems can be arranged in two ways. These include;

The parallel combination of springs

Series combination of springs

We will discuss them below;

Parallel Combination of Springs

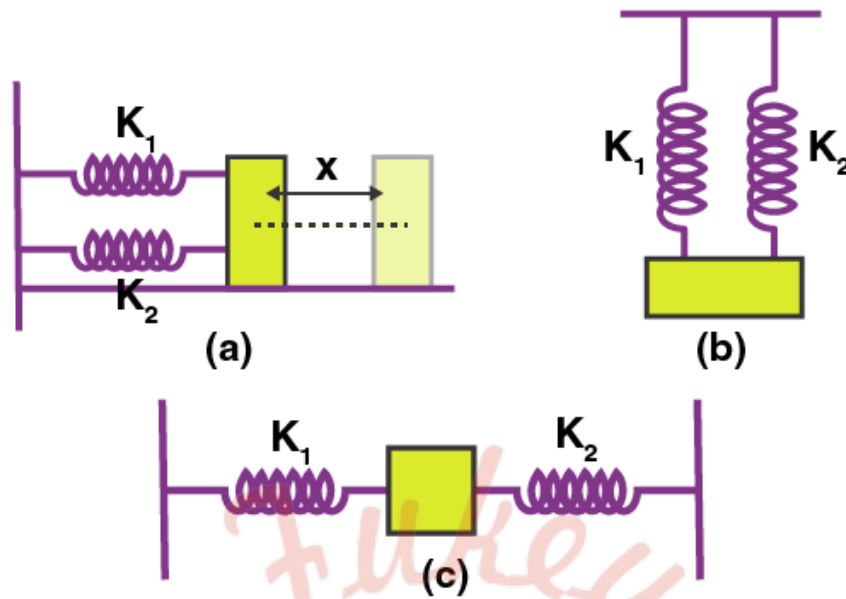

Fig (a), (b) and (c) – are the parallel combination of springs.

Displacement on each spring is the same.

But restoring force is different;

$$F = F_1 + F_2$$

Since, $F = -kx$, the above equation can be written as

$$\begin{aligned} \Rightarrow -k_p x &= -k_1 x - k_2 x \\ \Rightarrow -x k_p &= -x (k_1 + k_2) \\ \Rightarrow k_p &= k_1 + k_2 \end{aligned}$$

Time Period of Simple Pendulum Derivation

Using the equation of motion, $T - mg \cos\theta = mv^2/L$

The torque tending to bring the mass to its equilibrium position,

$$\tau = mgL \times \sin\theta = mg \sin\theta \times L = I \times \alpha$$

For small angles of oscillations $\sin \theta \approx \theta$,

Therefore, $I\alpha = -mgL\theta$

$$\alpha = -(mgL\theta)/I$$

$$-\omega_0^2 \theta = -(mgL\theta)/I$$

$$\omega_0^2 = (mgL)/I$$

$$\omega_0 = \sqrt{(mgL/I)}$$

Using $I = ML^2$, [where I denote the moment of inertia of bob]

$$\text{we get, } \omega_0 = \sqrt{(g/L)}$$

Therefore, the time period of a simple pendulum is given by,

$$T = 2\pi/\omega_0 = 2\pi \times \sqrt{L/g}$$

Top Formulae

Displacement in SHM	$y = a \sin (\omega t \pm \phi_0)$
Velocity in SHM	$v = \omega \sqrt{a^2 - y^2}$
Acceleration in SHM	$a = -\omega^2 y$ and $\omega = 2\pi \nu = 2\pi/T$
Potential energy in SHM	$U = \frac{1}{2} m \omega^2 a^2 = \frac{1}{2} k y^2$
Kinetic energy in SHM	$K = \frac{1}{2} m \omega^2 (a^2 - y^2) = \frac{1}{2} k (a^2 - y^2)$
Total energy	$E = \frac{1}{2} m \omega^2 a^2 = \frac{1}{2} k a^2$
Spring constant	$k = F/y$
Spring constant of parallel combination of springs	$k = k_1 + k_2$
Spring constant of series combination of springs	$\frac{1}{k} = \frac{1}{k_1} + \frac{1}{k_2}$
Time period	$T = 2\pi \sqrt{\frac{m}{K}}$
Equation of displacement in damped oscillation	<p>If the damping force is given by $F_d = -b v$, where v is the velocity of the oscillator and b is its damping constant, then the displacement of the oscillator is given by</p> $x(t) = A e^{-bt/2m} \cos (\omega' t + \Phi),$ <p>where ω' is the angular frequency of the damped oscillator and is given by</p> $\omega' = \sqrt{\frac{k}{m} - \frac{b^2}{4m^2}}$
Mechanical energy E of damped oscillator	$E(t) = \frac{1}{2} k A^2 e^{-bt/m}$

Class : 11th Physics
Chapter- 14 : Oscillations

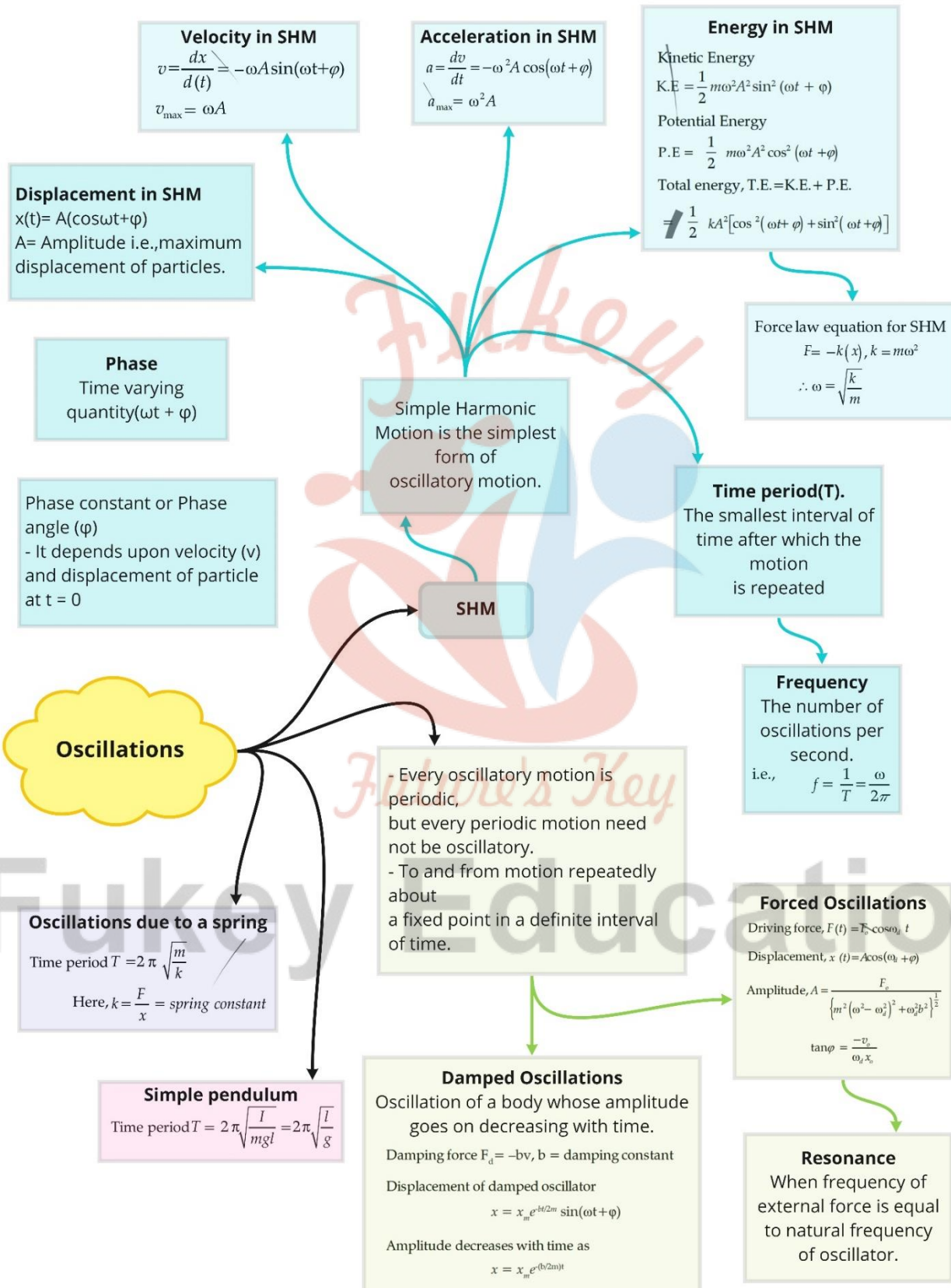

Important Questions

Multiple Choice questions-

Question 1. If an simple pendulum oscillates with an amplitude of 50 mm and time period of 2s, then its maximum velocity is

- (a) 0.10 m/s
- (b) 0.16 m/s
- (c) 0.25 m/s
- (d) 0.5 m/s

Question 2. If the frequency of the particle executing S.H.M. is n , the frequency of its kinetic energy becoming maximum is

- (a) $n/2$
- (b) n
- (c) $2n$
- (d) $4n$

Question 3. Spring is pulled down by 2 cm. What is amplitude of motion?

- (a) 0 cm
- (b) 6 cm
- (c) 2 cm
- (d) cm

Question 4. The period of thin magnet is 4 sec. if it is divided into two equal halves then the time period of each part will be

- (a) 4 sec
- (b) 1 sec
- (c) 2 sec
- (d) 8 sec

Question 5. The acceleration of particle executing S.H.M. when it is at mean position is

- (a) Infinite
- (b) Varies
- (c) Maximum
- (d) Zero

Question 6. A spring of force constant k is cut into two pieces such that one piece is double the length of the other. Then the long piece will have a force constant of

- (a) $2k/3$
- (b) $3k/2$
- (c) $3k$
- (d) $6k$

Question 7. Particle moves from extreme position to mean position, its

- (a) Kinetic energy increases, potential energy decreases
- (b) Kinetic energy decreases, potential energy increases
- (c) Both remain constant
- (d) Potential energy becomes zero and kinetic energy remains constant

Question 8. Graph of potential energy vs. displacement of a S.H. Oscillator is

- (a) parabolic
- (b) hyperbolic
- (c) elliptical
- (d) linear

Question 9. The time-period of S.H.O. is 16 sec. Starting from mean position, its velocity is 0.4 m/s after 2 sec. Its amplitude is

- (a) 0.36 m
- (b) 0.72 m
- (c) 1.44 m
- (d) 2.88 m

Question 10. A simple pendulum is made of a body which is a hollow sphere containing mercury suspended by means of a wire. If a little mercury is drained off, the period of pendulum will

- (a) Remain unchanged
- (b) Increase
- (c) Decrease
- (d) Become erratic

Assertion Reason Questions:

1. Directions:

- (a) If both assertion and reason are true and the reason is the correct

explanation of the assertion.

(b) If both assertion and reason are true but reason is not the correct explanation of the assertion.

(c) If assertion is true but reason is false.

(d) If the assertion and reason both are false

Assertion: Sine and cosine functions are periodic functions.

Reason: Sinusoidal functions repeats it values after a definite interval of time.

2. *Directions:*

(a) If both assertion and reason are true and the reason is the correct explanation of the assertion.

(b) If both assertion and reason are true but reason is not the correct explanation of the assertion.

(c) If assertion is true but reason is false.

(d) If the assertion and reason both are false

Assertion: Simple harmonic motion is a uniform motion.

Reason: Simple harmonic motion is not the projection of uniform circular motion.

MCQ Answers-

1. Answer: (b) 0.16 m/s

2. Answer: (c) $2n$

3. Answer: (c) 2 cm

4. Answer: (c) 2 sec

5. Answer: (d) Zero

6. Answer: (b) $3k/2$

7. Answer: (a) Kinetic energy increases, potential increases decreases

8. Answer: (a) parabolic

9. Answer: (c) 1.44 m

10. Answer: (b) Increase

Very Short Questions-

1. How is the time period effected, if the amplitude of a simple pendulum is in Creased?

2. Define force constant of a spring.

3. At what distance from the mean position, is the kinetic energy in simple harmonic oscillator equal to potential energy?
4. How is the frequency of oscillation related with the frequency of change in the of K. E and PE of the body in S.H.M.?
5. What is the frequency of total energy of a particle in S.H.M.?
6. How is the length of seconds pendulum related with acceleration due gravity of any planet?
7. If the bob of a simple pendulum is made to oscillate in some fluid of density greater than the density of air (density of the bob density of the fluid), then time period of the pendulum increased or decrease.
8. How is the time period of the pendulum effected when pendulum is taken to hills Or in mines?
9. Define angular frequency. Give its S.I. unit.
10. Does the direction of acceleration at various points during the oscillation of a simple pendulum remain towards mean position?

Very Short Answers- *Future's Key*

1. **Ans.** No effect on time period when amplitude of pendulum is increased or decreased.
2. **Ans.** The spring constant of a spring is the change in the force it exerts, divided by the change in deflection of the spring.
3. **Ans.** Not at the mid-point, between mean and extreme position. it will be at $x = a\sqrt{2}$.
4. **Ans.** P.E. or K.E. completes two vibrations in a time during which S.H.M completes one vibration or the frequency of P.E. or K.E. is double than that of S.H.M
5. **Ans.** The frequency of total energy of particle is S.H.M is zero because it retain constant.
6. **Ans.** Length of the seconds pendulum proportional to acceleration due to gravity)

7. **Ans.** Increased

8. **Ans.** As $T \propto \frac{1}{\sqrt{g}}$, T will increase.

9. **Ans.** It is the angle covered per unit time or it is the quantity obtained by multiplying frequency by a factor of 2π .

$$\omega = 2\pi \nu, \text{ S.I. unit is } \text{rads s}^{-1}$$

10. **Ans.** No, the resultant of Tension in the string and weight of bob is not always towards the mean position.

Short Questions-

1. A mass = m suspend separately from two springs of spring constant k_1 and k_2 gives time period t_1 and t_2 respectively. If the same mass is connected to both the springs as shown in figure. Calculate the time period 't' of the combined system?

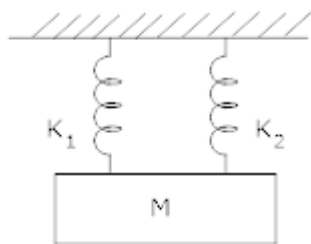

2. Show that the total energy of a body executing SHM is independent of time?

3. A particle moves such that its acceleration 'a' is given by $a = -bx$ where $x =$ displacement from equilibrium position and b is a constant. Find the period of oscillation? 2

4. A particle in S.H.M. is described by the displacement function: \rightarrow

$$x = A \cos(\omega t + \Phi); \omega = \frac{2\pi}{T}$$

If the initial ($t = 0$) position of the particle is 1 cm and its initial velocity is π cm/s, What are its amplitude and phase angle?

5. Determine the time period of a simple pendulum of length = l when mass of bob = m Kg? 3

6. Which of the following examples represent periodic motion?

- (a) A swimmer completing one (return) trip from one bank of a river to the other and back.
- (b) A freely suspended bar magnet displaced from its N-S direction and released.
- (c) A hydrogen molecule rotating about its center of mass.

(d) An arrow released from a bow.

7. Figure 14.27 depicts four $x-t$ plots for linear motion of a particle. Which of the plots represent periodic motion? What is the period of motion (in case of periodic motion)?

(a)

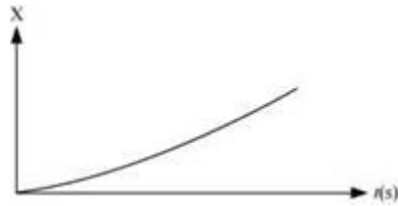

(b)

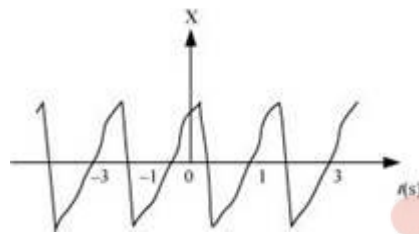

(c)

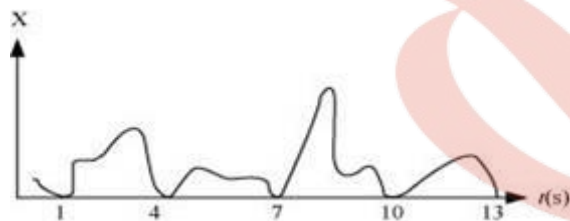

(d)

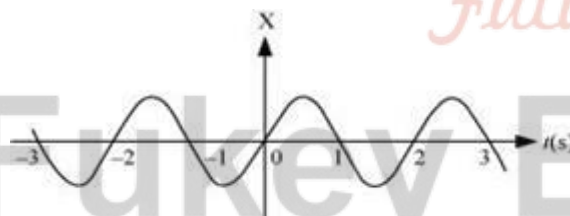

8. Which of the following relationships between the acceleration a and the displacement x of a particle involve simple harmonic motion?

(a) $a = 0.7x$

(b) $a = -200x^2$

(c) $a = -10x$

(d) $a = 100x^3$

9. The acceleration due to gravity on the surface of moon is 1.7 ms^{-2} . What is the time period of a simple pendulum on the surface of moon if its time period on the surface of earth is 3.5 s? (g on the surface of earth is 9.8 ms^{-2})

10. A simple pendulum of length l and having a bob of mass M is suspended in a car. The car is moving on a circular track of radius R with a uniform speed v . If the pendulum makes small oscillations in a radial direction about its equilibrium position, what will be its time period?

Short Answers-

1. **Ans.** If T = Time Period of simple pendulum

m = Mass

k = Spring constant

$$\text{then, } T = 2\pi\sqrt{\frac{m}{k}}$$

$$\text{or } k = \frac{4\pi^2 m}{T^2}$$

$$\text{For first spring : } \rightarrow k_1 = \frac{4\pi^2 m}{t_1^2} \text{ let } T = t_1$$

$$\text{For second spring : } \rightarrow k_2 = \frac{4\pi^2 m}{t_2^2} \text{ let } T = t_2$$

When springs is connected in parallel, effective spring constant, $k = k = k_1 + k_2$

$$\text{or } k = \frac{4\pi^2 m}{t_1^2} + \frac{4\pi^2 m}{t_2^2}$$

If t = total time period

$$\frac{4\pi^2 m}{t^2} = \frac{4\pi^2 m}{t_1^2} + \frac{4\pi^2 m}{t_2^2}$$

$$\frac{1}{t^2} = \frac{1}{t_1^2} + \frac{1}{t_2^2}$$

$$\text{Or } t^{-2} = t_1^{-2} + t_2^{-2}$$

2. **Ans.** Let y = displacement at any time 't'

a = amplitude

w = Angular frequency

v = velocity,

$y = a \sin wt$

$$v = \frac{dy}{dt} = \frac{d}{dt} (a \sin wt)$$

So, $v = a w \cos wt$

Now, kinetic energy = K. E. = $\frac{1}{2} m v^2$

$$K.E. = \frac{1}{2} m \omega^2 a^2 \cos^2 \omega t \rightarrow 1)$$

Potential energy = $\frac{1}{2} k y^2$

$$P.E. = \frac{1}{2} k a^2 \sin^2 \omega t \rightarrow 2)$$

Adding equation 1) & 2)

Total energy = K.E. + P.E

$$= \frac{1}{2} m \omega^2 a^2 \cos^2 \omega t + \frac{1}{2} k a^2 \sin^2 \omega t$$

$$\text{Since } \omega = \sqrt{\frac{k}{m}} \Rightarrow \omega^2 m = k^2$$

$$\text{Total energy} = \frac{1}{2} m \omega^2 a^2 \cos^2 \omega t + \frac{1}{2} k a^2 \sin^2 \omega t$$

$$= \frac{1}{2} k a^2 \cos^2 \omega t + \frac{1}{2} k a^2 \sin^2 \omega t$$

$$= \frac{1}{2} k a^2 (\cos^2 \omega t + \sin^2 \omega t)$$

$$\text{Total energy} = \frac{1}{2} k a^2$$

Thus total mechanical energy is always constant is equal to $\frac{1}{2} k a^2$. The total energy is independent to time. The potential energy oscillates with time and has a

maximum value of $\frac{k a^2}{2}$. Similarly K. E. oscillates with time and has a maximum

value of $\frac{k a^2}{2}$. At any instant = constant = $\frac{k a^2}{2}$. The K. E or P.E. oscillates at double the frequency of S.H.M.

3. Ans. Given that $a = -b x$, Since $a \propto x$ and is directed opposite to x , the particle do moves in S. H. M.

$a = b x$ (in magnitude)

$$\text{or } \frac{x}{a} = \frac{1}{b}$$

$$\text{or } \frac{\text{Displacement}}{\text{Acceleration}} = \frac{1}{b} \rightarrow 1)$$

$$\text{Time period} = T = 2\pi \sqrt{\frac{\text{Displacement}}{\text{Acceleration}}}$$

Using equation 1)

$$T = 2\pi \sqrt{\frac{1}{b}}$$

4. Ans. At $t = 0$; $x = 1\text{cm}$; $w = \pi\text{s}$

$t = \text{time}$

$x = \text{Position}$

$w = \text{Angular frequency}$

$$\therefore x = A \cos (Wt + \phi)$$

$$1 = A \cos (\pi \times 0 + \phi)$$

$$1 = A \cos \phi$$

$$\text{Now, } v = \frac{dx}{dt} = \frac{d}{dt} (A \cos (wt + \phi))$$

$$\text{At } t = 0 \quad v = \pi \text{ cm/s}; \quad w = \pi\text{s}$$

$$v = -A\omega \sin (\pi \times 0 + \phi)$$

$$\Rightarrow -1 = A \sin \phi \rightarrow 2)$$

Squaring and adding 1) & 2)

$$A^2 \cos^2 \phi + A^2 \sin^2 \phi = 1 + 1$$

$$A^2 (\cos^2 \phi + \sin^2 \phi) = 2$$

$$A^2 = 2$$

$$A = \sqrt{2} \text{cm}$$

Dividing 2) by 1), we have :-

$$\frac{A \sin \phi}{A \cos \phi} = -1$$

$$\tan \phi = -1$$

$$\text{or } \phi = \tan^{-1}(-1)$$

$$\phi = \frac{3\pi}{4}$$

5. Ans. It consist of a heavy point mass body suspended by a weightless inextensible and perfectly flexible string from a rigid support which is free to oscillate.

The distance between point of suspension and point of oscillation is effective length of pendulum.

M = Mass of Bob

x = Displacement = OB

l = length of simple pendulum

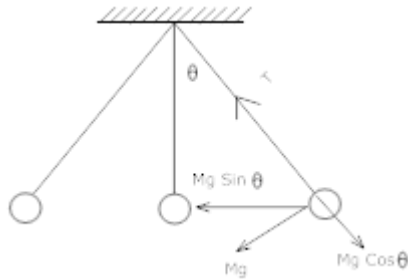

Let the bob is displaced through a small angle θ the forces acting on it:-

1) weight = Mg acting vertically downwards.

2) Tension = T acting upwards.

Divide Mg into its components $\rightarrow Mg \cos \theta$ & $Mg \sin \theta$

$$T = Mg \cos \theta$$

$$F = Mg \sin \theta$$

-ve sign shows force is directed towards the mean position. If θ = Small,

$$\sin \theta \cong \theta = \frac{\text{Arc } OB}{l} = \frac{x}{l}$$

$$F = -Mg \frac{x}{l}$$

In S.H.M., restoring force, $F = -mg \theta$ $F = -mg \frac{x}{l} \rightarrow 1$

Also, if k = spring constant

$$F = -kx$$

$$-mg \frac{x}{l} = -kx \left(\text{equating } F = -mg \frac{x}{l} \right)$$

$$k = \frac{mg}{l}$$

$$T = 2\pi \sqrt{\frac{m}{k}}$$

$$= 2\pi \sqrt{\frac{m \times l}{mg}}$$

$$T = 2\pi \sqrt{\frac{l}{g}}$$

i.e.1.) Time period depends on length of pendulum and 'g' of place where experiment is done.

2) T is independent of amplitude of vibration provided and it is small and also of the mass of bob.

6. Ans. (b) and (c)

(a) The swimmer's motion is not periodic. The motion of the swimmer between the banks of a river is back and forth. However, it does not have a definite period. This is because the time taken by the swimmer during his back and forth journey may not be the same.

(b) The motion of a freely-suspended magnet, if displaced from its N-S direction and released, is periodic. This is because the magnet oscillates about its position with a definite period of time.

(c) When a hydrogen molecule rotates about its centre of mass, it comes to the same position again and again after an equal interval of time. Such motion is periodic.

(d) An arrow released from a bow moves only in the forward direction. It does not come backward. Hence, this motion is not a periodic.

7. Ans. (b) and (d) are periodic

(a) It is not a periodic motion. This represents a unidirectional, linear uniform motion. There is no repetition of motion in this case.

(b) In this case, the motion of the particle repeats itself after 2 s. Hence, it is a periodic motion, having a period of 2 s.

(c) It is not a periodic motion. This is because the particle repeats the motion in one position only. For a periodic motion, the entire motion of the particle must be repeated in equal intervals of time.

(d) In this case, the motion of the particle repeats itself after 2 s. Hence, it is a periodic motion, having a period of 2 s.

8. Ans. (c) A motion represents simple harmonic motion if it is governed by the force law:

$$F = -kx$$

$$ma = -kx$$

$$\therefore a = -\frac{k}{m}x$$

Where,

F is the force

m is the mass (a constant for a body)

x is the displacement

a is the acceleration

k is a constant

Among the given equations, only equation $a = -10x$ is written in the above form

with $\frac{k}{m} = 10$
Hence, this relation represents SHM.

9. Ans. Acceleration due to gravity on the surface of moon, $g' = 1.7 \text{ m s}^{-2}$

Acceleration due to gravity on the surface of earth, $g = 9.8 \text{ m s}^{-2}$

Time period of a simple pendulum on earth, $T = 3.5 \text{ s}$

$$T = 2\pi \sqrt{\frac{l}{g}}$$

Where,

l is the length of the pendulum

$$\begin{aligned} \therefore l &= \frac{T^2}{(2\pi)^2} \times g \\ &= \frac{(3.5)^2}{4 \times (3.14)^2} \times 9.8 \text{ m} \end{aligned}$$

The length of the pendulum remains constant.

On moon's surface, time period, $T' = 2\pi \sqrt{\frac{l}{g'}}$

$$= 2\pi \sqrt{\frac{\frac{(3.5)^2}{4 \times (3.14)^2} \times 9.8}{1.7}} = 8.4 \text{ s}$$

Hence, the time period of the simple pendulum on the surface of moon is 8.4 s.

10. Ans. The bob of the simple pendulum will experience the acceleration due to gravity and the centripetal acceleration provided by the circular motion of the car.

Acceleration due to gravity = g

Centripetal acceleration = $\frac{v^2}{R}$

Where,

v is the uniform speed of the car

R is the radius of the track

Effective acceleration (a_{eff}) is given as:

$$a_{\text{eff}} = \sqrt{g^2 + \left(\frac{v^2}{R}\right)^2}$$

Time period, $T = 2\pi \sqrt{\frac{l}{a_{\text{eff}}}}$

Where, l is the length of the pendulum

$$= 2\pi \sqrt{\frac{l}{g^2 + \frac{v^4}{R^2}}}$$

\therefore Time period, T

Long questions-

1. What is Simple pendulum? Find an expression for the time period and frequency of a simple pendulum?

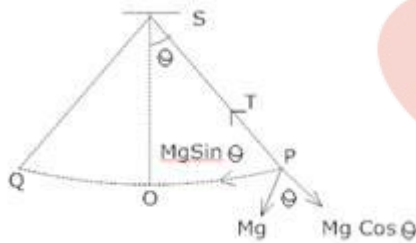

2. A particle is in linear simple harmonic motion between two points, A and B, 10 cm apart. Take the direction from A to B as the positive direction and give the signs of velocity, acceleration and force on the particle when it is

- at the end A,
- at the end B,
- at the mid-point of AB going towards A,
- at 2 cm away from B going towards A,
- at 3 cm away from A going towards B, and
- at 4 cm away from B going towards A.

3. The motion of a particle executing simple harmonic motion is described by the displacement function,

$$x(t) = A \cos(\omega t + \phi).$$

If the initial ($t = 0$) position of the particle is 1 cm and its initial velocity is ω cm/s, what are its amplitude and initial phase angle? The angular frequency of the particle is π s⁻¹. If

instead of the cosine function, we choose the sine function to describe the SHM: $x = B \sin(\omega t + \alpha)$, what are the amplitude and initial phase of the particle with the above initial conditions.

4. In Exercise 14.9, let us take the position of mass when the spring is unstretched as $x = 0$, and the direction from left to right as the positive direction of x -axis. Give x as a function of time t for the oscillating mass if at the moment we start the stopwatch ($t = 0$), the mass is

- at the mean position,
- at the maximum stretched position, and
- at the maximum compressed position.

In what way do these functions for SHM differ from each other, in frequency, in amplitude or the initial phase?

5. Plot the corresponding reference circle for each of the following simple harmonic motions. Indicate the initial ($t = 0$) position of the particle, the radius of the circle, and the angular speed of the rotating particle. For simplicity, the sense of rotation may be fixed to be anticlockwise in every case: (x is in cm and t is in s).

- $x = -2 \sin(3t + \pi/3)$
- $x = \cos(\pi/6 - t)$
- $x = 3 \sin(2\pi t + \pi/4)$
- $x = 2 \cos \pi t$

6. Figure 14.30 (a) shows a spring of force constant k clamped rigidly at one end and a mass m attached to its free end. A force F applied at the free end stretches the spring. Figure 14.30 (b) shows the same spring with both ends free and attached to a mass m at either end. Each end of the spring in Fig. 14.30(b) is stretched by the same force F .

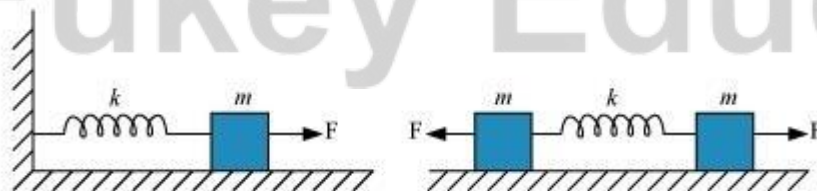

- What is the maximum extension of the spring in the two cases?
- If the mass in Fig. (a) and the two masses in Fig. (b) are released, what is the period of oscillation in each case?

7. One end of a U-tube containing mercury is connected to a suction pump and the other end to atmosphere. A small pressure difference is maintained between the two columns. Show that, when the suction pump is removed, the column of mercury in the U-tube executes simple harmonic motion.

8. An air chamber of volume V has a neck area of cross section a into which a ball of mass m just fits and can move up and down without any friction (Fig.14.33). Show that when the ball is pressed down a little and released, it executes SHM. Obtain an expression for the time period of oscillations assuming pressure-volume variations of air to be isothermal see Fig.14.33.

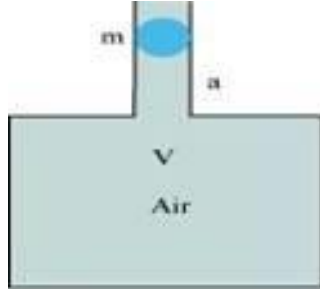

Long Answers-

1. Ans. A simple pendulum is the most common example of the body executing S.H.M, it consists of a heavy point mass body suspended by a weightless inextensible and perfectly flexible string from a rigid support, which is free to oscillate.

Let m = mass of bob

l = length of pendulum

Let O is the equilibrium position, $OP = x$

Let θ = small angle through which the bob is displaced.

The forces acting on the bob are:-

1) The weight = Mg acting vertically downwards.

2) The tension = T in string acting along Ps .

Resolving Mg into 2 components as $Mg \cos \theta$ and $Mg \sin \theta$,

Now, $T = Mg \cos \theta$

Restoring force $F = - Mg \sin \theta$

-ve sign shows force is directed towards mean position.

Let θ = Small, so $\sin \theta \approx \theta = \frac{\text{Arc(op)}}{1} = \frac{x}{l}$

Hence $F = - mg \theta$

$F = - mg \frac{x}{l} \rightarrow 3)$

Now, In S.H.M, $F = kx \rightarrow 4)$ k = Spring constant

Equating equation 3) & 4) for F

$$-kx = -mg \frac{x}{l}$$

$$\text{Spring factor} = k = \frac{mg}{l}$$

Inertia factor = Mass of bob = m

Now, Time period = T

$$= 2\pi \sqrt{\frac{\text{Inertia factor}}{\text{Spring factor}}}$$

$$= 2\pi \sqrt{\frac{m}{mg/l}}$$

$$T = 2\pi \sqrt{\frac{l}{g}}$$

2. Ans.(a) Zero, Positive, Positive

(b) Zero, Negative, Negative

(c) Negative, Zero, Zero

(d) Negative, Negative, Negative

(e) Zero, Positive, Positive

(f) Negative, Negative, Negative

Explanation:

The given situation is shown in the following figure. Points A and B are the two end points, with $AB = 10$ cm. O is the midpoint of the path.



A particle is in linear simple harmonic motion between the end points

(a) At the extreme point A, the particle is at rest momentarily. Hence, its velocity is zero at this point.

Its acceleration is positive as it is directed along AO.

Force is also positive in this case as the particle is directed rightward.

(b) At the extreme point B, the particle is at rest momentarily. Hence, its velocity is zero at this point.

Its acceleration is negative as it is directed along B.

Force is also negative in this case as the particle is directed leftward.

(c)

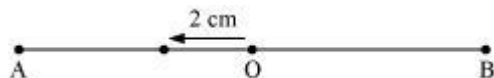

The particle is executing a simple harmonic motion. O is the mean position of the particle. Its velocity at the mean position O is the maximum. The value for velocity is negative as the particle is directed leftward. The acceleration and force of a particle executing SHM is zero at the mean position.

(d)



The particle is moving toward point O from the end B. This direction of motion is opposite to the conventional positive direction, which is from A to B. Hence, the particle's velocity and acceleration, and the force on it are all negative.

(e)

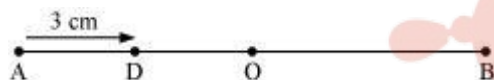

The particle is moving toward point O from the end A. This direction of motion is from A to B, which is the conventional positive direction. Hence, the values for velocity, acceleration, and force are all positive.

(f)



This case is similar to the one given in (d).

3. Ans. Initially, at $t = 0$:

Displacement, $x = 1$ cm

Initial velocity, $v = \omega$ cm/sec.

Angular frequency, $\omega = \pi$ rad/ s^{-1}

It is given that:

$$x(x) = A \cos(\omega t + \phi)$$

$$1 = A \cos(\omega \times 0 + \phi) = A \cos \phi$$

$$A \cos \phi = 1 \dots (i)$$

$$\text{Velocity, } v = \frac{dx}{dt}$$

$$\omega = -A\omega \sin(\omega t + \phi)$$

$$1 = A \sin(\omega \times 0 + \phi) = A \sin \phi$$

$$A \sin \phi = -1 \dots\dots(ii)$$

Squaring and adding equations (i) and (ii), we get:

$$A^2 (\sin^2 \phi + \cos^2 \phi) = 1 + 1$$

$$A^2 = 2$$

$$\therefore A = \sqrt{2} \text{ cm}$$

Dividing equation (ii) by equation (i), we get:

$$\tan \phi = -1$$

$$\therefore \phi = \frac{3\pi}{4}, \frac{7\pi}{4}, \dots\dots$$

SHM is given as:

$$x = B \sin(\omega t + \alpha)$$

Putting the given values in this equation, we get:

$$1 = B \sin[\omega \times 0 + \alpha]$$

$$B \sin \alpha = 1 \dots\dots(iii)$$

Velocity, $v = \omega B \cos(\omega t + \alpha)$

Substituting the given values, we get:

$$\pi = \pi B \sin \alpha$$

$$B \sin \alpha = 1 \dots\dots(iv)$$

Squaring and adding equations (iii) and (iv), we get:

$$B^2 [\sin^2 \alpha + \cos^2 \alpha] = 1 + 1$$

$$B^2 = 2$$

$$\therefore B = \sqrt{2} \text{ cm}$$

Dividing equation (iii) by equation (iv), we get:

$$\frac{B \sin \alpha}{B \cos \alpha} = \frac{1}{1}$$

$$\tan \alpha = 1 = \tan \frac{\pi}{4}$$

$$a \frac{\pi}{4}, \frac{5\pi}{4}, \dots$$

4. Ans. (a) $x = 2\sin 20t$

(b) $x = 2\cos 20t$

(c) $x = -2\cos 20t$

The functions have the same frequency and amplitude, but different initial phases.

Distance travelled by the mass sideways, $A = 2.0$ cm

Force constant of the spring, $k = 1200 \text{ N m}^{-1}$

Mass, $m = 3$ kg

Angular frequency of oscillation:

$$\begin{aligned} \omega &= \sqrt{\frac{k}{m}} \\ &= \sqrt{\frac{1200}{3}} = \sqrt{400} = 20 \text{ rad s}^{-1} \end{aligned}$$

(a) When the mass is at the mean position, initial phase is 0.

Displacement, $x = A \sin \omega t$

$$= 2\sin 20t$$

(b) At the maximum stretched position, the mass is toward the extreme right. Hence, the

initial phase is $\frac{\pi}{2}$.

Displacement, $x = A \sin \left(\omega t + \frac{\pi}{2} \right)$

$$= 2 \sin \left(20t + \frac{\pi}{2} \right)$$

$$= 2\cos 20t$$

(c) At the maximum compressed position, the mass is toward the extreme left. Hence, the

initial phase is $\frac{3\pi}{2}$.

Displacement, $x = A \sin \left(\omega t + \frac{3\pi}{2} \right)$

$$= 2 \sin \left(20t + \frac{3\pi}{2} \right)$$

$$= -2\cos 20t$$

The functions have the same frequency $\left(\frac{20}{2\pi} \text{ Hz}\right)$ and amplitude (2 cm), but different initial phases $\left(0, \frac{\pi}{2}, \frac{3\pi}{2}\right)$.

5. Ans.(a)

$$x = -2 \sin\left(3t + \frac{\pi}{3}\right) = +2 \cos\left(3t + \frac{\pi}{3} + \frac{\pi}{2}\right)$$

$$= 2 \cos\left(3t + \frac{5\pi}{6}\right)$$

If this equation is compared with the standard SHM equation $x = A \cos\left(\frac{2\pi}{T}t + \phi\right)$, then we get:

Amplitude, $A = 2 \text{ cm}$

Phase angle, $\phi = \frac{5\pi}{6} = 150^\circ$

Angular velocity, $\omega = \frac{2\pi}{T} = 3 \text{ rad/sec.}$

The motion of the particle can be plotted as shown in the following figure.

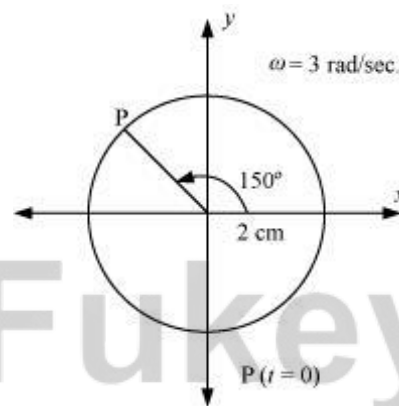

(b)

$$x = \cos\left(\frac{\pi}{6} - t\right) = \cos\left(t - \frac{\pi}{6}\right)$$

If this equation is compared with the standard SHM equation $x = A \cos\left(\frac{2\pi}{T}t + \phi\right)$, then we get:

Amplitude, $A=2$

Phase angle, $\phi = \frac{\pi}{6} = 30^\circ$

Angular velocity, $\omega = \frac{2\pi}{T} = 1 \text{ rad/sec.}$

The motion of the particle can be plotted as shown in the following figure.

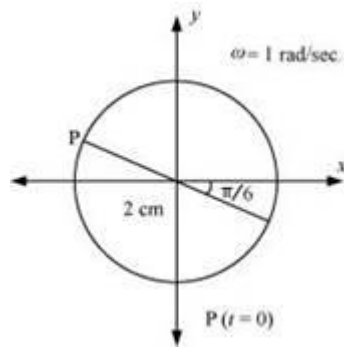

(c) $x = 3 \sin\left(2\pi t + \frac{\pi}{4}\right)$

$$= -3 \cos\left[\left(2\pi t + \frac{\pi}{4}\right) + \frac{\pi}{2}\right] = -3 \cos\left(2\pi t + \frac{3\pi}{4}\right)$$

If this equation is compared with the standard SHM equation

$$x = A \cos\left(\frac{2\pi}{T}t + \phi\right), \text{ then we get:}$$

Amplitude, $A = 3 \text{ cm}$

Phase angle, $\phi = \frac{3\pi}{4} = 135^\circ$

Angular velocity, $\omega = \frac{2\pi}{T} = 2\pi \text{ rad/sec.}$

The motion of the particle can be plotted as shown in the following figure.

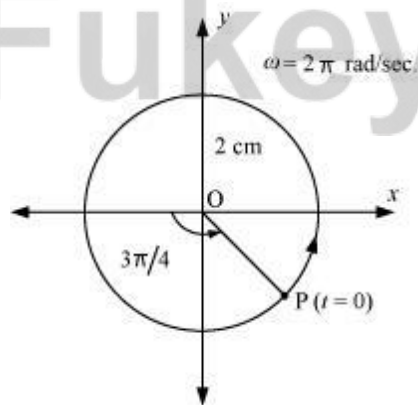

(d) $x = 2 \cos \pi t$

If this equation is compared with the standard SHM equation

$$x = A \cos\left(\frac{2\pi}{T}t + \phi\right), \text{ then we get:}$$

Amplitude, $A = 2 \text{ cm}$

Phase angle, $\phi = 0$

Angular velocity, $\omega = \pi \text{ rad/s}$

The motion of the particle can be plotted as shown in the following figure.

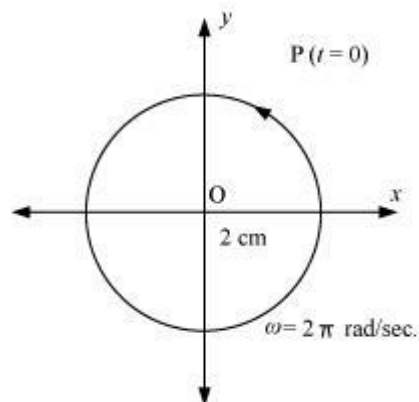

6. Ans.(a) For the one block system:

When a force F , is applied to the free end of the spring, an extension l , is produced. For the maximum extension, it can be written as:

$$F = kl$$

Where, k is the spring constant

Hence, the maximum extension produced in the spring, $l = \frac{F}{k}$

For the two block system:

The displacement (x) produced in this case is:

$$x = \frac{1}{2}$$

Net force, $F = +2kx$

$$\therefore l = \frac{F}{k}$$

(b) For the one block system:

For mass (m) of the block, force is written as:

$$F = ma = m \frac{d^2x}{dt^2}$$

Where, x is the displacement of the block in time t

$$\therefore m \frac{d^2x}{dt^2} = -kx$$

It is negative because the direction of elastic force is opposite to the direction of displacement.

$$\frac{d^2x}{dt^2} = -\left(\frac{k}{m}\right)x = -\omega^2x$$

Where, $\omega^2 = \frac{k}{m}$

$$\omega = \sqrt{\frac{k}{m}}$$

Where,

ω is angular frequency of the oscillation

\therefore Time period of the oscillation, $T = \frac{2\pi}{\omega}$

$$= \frac{2\pi}{\sqrt{\frac{k}{m}}} = 2\pi\sqrt{\frac{m}{k}}$$

For the two block system:

$$F = m \frac{d^2x}{dt^2}$$

$$m \frac{d^2x}{dt^2} = -2kx$$

It is negative because the direction of elastic force is opposite to the direction of displacement.

$$\frac{d^2x}{dt^2} = -\left[\frac{2k}{m}\right]x = -\omega^2x$$

Where,

Angular frequency, $\omega = \sqrt{\frac{2k}{m}}$

\therefore Time period, $T = \frac{2\pi}{\omega} = 2\pi\sqrt{\frac{m}{2k}}$

7. Ans. Area of cross-section of the U-tube = A

Density of the mercury column = ρ

Acceleration due to gravity = g

Restoring force, F = Weight of the mercury column of a certain height

$$F = -(\text{Volume} \times \text{Density} \times g)$$

$$F = -(A \times 2h \times \rho \times g) = -2\rho gh = -k \times \text{Displacement in one of the arms } (h)$$

Where,

$2h$ is the height of the mercury column in the two arms

$$k \text{ is a constant, given by } k = -\frac{F}{h} = 2A\rho g$$

$$\text{Time period, } T = 2\pi\sqrt{\frac{m}{k}} = 2\pi\sqrt{\frac{m}{2A\rho g}}$$

Where,

m is the mass of the mercury column

Let l be the length of the total mercury in the U-tube.

Mass of mercury, m = Volume of mercury \times Density of mercury

$$= Al\rho$$

$$\therefore T = 2\pi\sqrt{\frac{m}{2A\rho g}} = 2\pi\sqrt{\frac{l}{2g}}$$

Hence, the mercury column executes simple harmonic motion with time period $2\pi\sqrt{\frac{l}{2g}}$.

8. Ans. Volume of the air chamber = V

Area of cross-section of the neck = a

Mass of the ball = m

The pressure inside the chamber is equal to the atmospheric pressure.

Let the ball be depressed by x units. As a result of this depression, there would be a decrease in the volume and an increase in the pressure inside the chamber.

Decrease in the volume of the air chamber, $\Delta V = ax$

$$\text{Volumetric strain} = \frac{\text{Change in volume}}{\text{Original volume}}$$

$$\Rightarrow \frac{\Delta V}{V} = \frac{ax}{V}$$

$$B = \frac{\text{Stress}}{\text{Strain}} = \frac{-p}{\frac{\Delta x}{V}}$$

Bulk Modulus of air,

In this case, stress is the increase in pressure. The negative sign indicates that pressure increases with a decrease in volume.

$$p = \frac{-B\Delta x}{V}$$

The restoring force acting on the ball, $F = p \times a$

$$\begin{aligned} & \frac{-B\Delta x}{V} \cdot a \\ &= \frac{-B\Delta^2 x}{V} \end{aligned}$$

In simple harmonic motion, the equation for restoring force is:

$$F = -kx \dots (ii)$$

Where, k is the spring constant

Comparing equations (i) and (ii), we get:

$$= \frac{Ba^2}{V}$$

$$\text{Time period, } T = 2\pi\sqrt{\frac{m}{k}}$$

$$= 2\pi\sqrt{\frac{Vm}{Ba^2}}$$

Assertion Reason Answer:

- (a) If both assertion and reason are true but reason is not the correct explanation of the assertion.
- (d) If the assertion and reason both are false.

Case Study Questions-

- A motion that repeats itself at regular intervals of time is called periodic motion. Very often, the body undergoing periodic motion has an equilibrium position somewhere inside its path. When the body is at this position no net external force acts on it. Therefore, if it is left there at rest, it remains there forever. If the body is given a small displacement from the position, a force comes into play which tries to bring the body periodic motion need not be oscillatory. Circular motion is a periodic motion, but it is not oscillatory. The smallest interval of time after which the motion is repeated is called its period. Let us denote the period by the symbol T . Its SI unit is second. The reciprocal of T gives the

number of repetitions that occur per unit time. This quantity is called the frequency of the periodic motion. It is represented by the symbol n . The waves, Heinrich Rudolph Hertz (1857–1894), a special name has been given to the unit of frequency. It is called hertz (abbreviated as Hz). Answer the following.a)

- i. Every oscillatory motion is periodic motion true or false?
 - a. True
 - b. False
 - ii. Circular motion is
 - a. Oscillatory motion
 - b. Periodic motion
 - c. Rotational motion
 - d. None of these
 - iii. Define period. Give its SI unit and dimensions
 - iv. Define frequency of periodic motion. How it is related to time period
 - v. What is oscillatory motion
2. When a system (such as a simple pendulum or a block attached to a spring) is displaced from its equilibrium position and released, it oscillates with its natural frequency ω , and the oscillations are called free oscillations. All free oscillations eventually die out because of the ever present damping forces. However, an external agency can maintain these oscillations. These are called forced or driven oscillations. We consider the case when the external force is itself fact of forced periodic oscillations is that the system oscillates not with its natural frequency ω , but at familiar example of forced oscillation is when a child in a garden swing periodically presses his feet against the ground (or someone else periodically gives the child a push) to maintain the oscillations. The maximum possible amplitude for a given driving frequency is governed by the driving frequency and the damping, and is never infinity. The phenomenon of increase in amplitude when the driving force is close to the natural frequency of the oscillator is experience with swings is a good example of resonance. You might have realized that the skill in swinging to greater heights lies in the synchronization of the rhythm of pushing against the ground with the natural frequency of the swing.
- i. When a system oscillates with its natural frequency ω , and the oscillations are called
 - a. Free oscillations
 - b. Forced oscillations
 - ii. All free oscillations eventually die out because of
 - a. Damping force

- b. electromagnetic force
- c. None of these
- iii. What is free oscillation?
- iv. What is forced oscillations?
- v. What is resonance?

Case Study Answer-

1. Answer

- i. (a) True
- ii. (b) Periodic motion
- iii. The smallest interval of time after which the motion is repeated is called its period. Its SI unit is second and dimensions are $[T^1]$.
- iv. Reciprocal of Time period (T) gives the number of repetitions that occur per unit time. This quantity is called the frequency of the periodic motion. It is represented by the symbol n . The relation between n and T is $n = 1/T$ i.e. they are inversely proportional to each other. The unit of n is thus s^{-1} or hertz.
- v. Oscillatory motion is type of periodic motion in which body performs periodic to and fro motion about some mean position. Every oscillatory motion is periodic, but every periodic motion need not be oscillatory.

2. Answer

- i. (a) Free oscillations
- ii. (b) Damping force
- iii. When a system (such as a simple pendulum or a block attached to a spring) is displaced from its equilibrium position and released, it oscillates with its natural frequency ω , and the oscillations are called free oscillations.
- iv. Forced oscillations are oscillations where external force drives the oscillations with frequency given by external force.
- v. The phenomenon of increase in amplitude when the driving force is close to encounter phenomena which involve resonance. Your experience with swings is a good example of resonance. You might have realized that the skill in swinging to greater heights lies in the synchronization of the rhythm of pushing against the ground with the natural frequency of the swing.