

# MATHEMATICS

## Chapter 11: Three-Dimensional Geometry

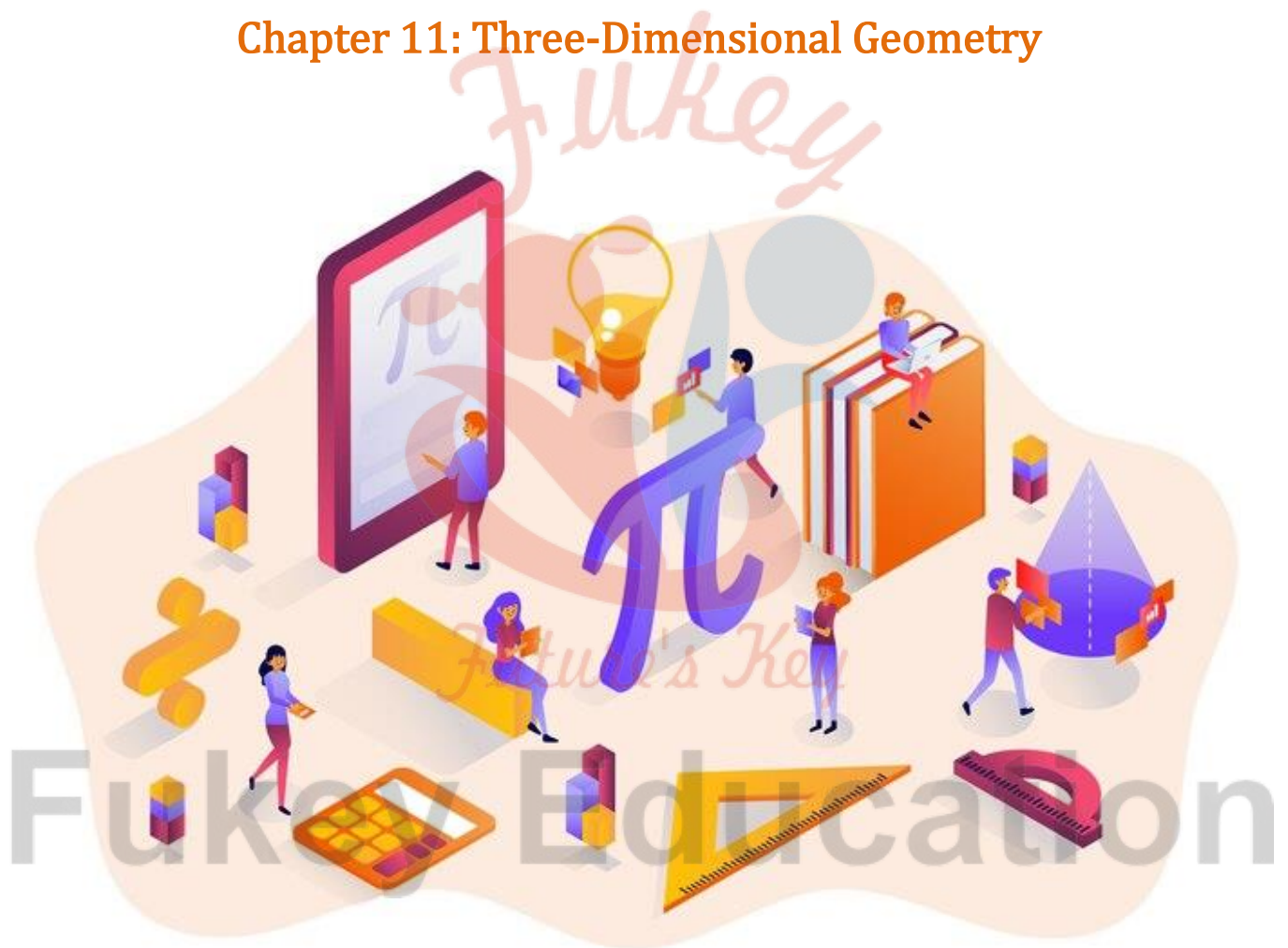

## THREE-DIMENSIONAL GEOMETRY

### Top Review

1. If  $P(x_1, y_1, z_1)$  and  $Q(x_2, y_2, z_2)$  are two points in space, then

$$PQ = \sqrt{(x_2 - x_1)^2 + (y_2 - y_1)^2 + (z_2 - z_1)^2}$$

2. The distance of a point  $P(x_1, y_1, z_1)$  from the origin  $O$  is given by

$$OP = \sqrt{x_1^2 + y_1^2 + z_1^2}$$

3. The coordinates of a point  $R$  which divides the line joining the points  $P(x_1, y_1, z_1)$  and  $Q(x_2, y_2, z_2)$  internally in the ratio  $m : n$  are

$$\left( \frac{mx_2 + nx_1}{m+n}, \frac{my_2 + ny_1}{m+n}, \frac{mz_2 + nz_1}{m+n} \right).$$

4. The coordinates of a point  $R$  which divides the line joining the points  $P(x_1, y_1, z_1)$  and  $Q(x_2, y_2, z_2)$  externally in the ratio  $m : n$  are

$$\left( \frac{mx_2 - nx_1}{m-n}, \frac{my_2 - ny_1}{m-n}, \frac{mz_2 - nz_1}{m-n} \right).$$

5. Let  $P(x_1, y_1, z_1)$  and  $Q(x_2, y_2, z_2)$  be two points in space. The coordinates of the midpoint of  $PQ$

$$\text{are } \left( \frac{x_1 + x_2}{2}, \frac{y_1 + y_2}{2}, \frac{z_1 + z_2}{2} \right).$$

6. Let  $P(x_1, y_1, z_1)$ ,  $Q(x_2, y_2, z_2)$  and  $R(x_3, y_3, z_3)$  be three vertices of the triangle.

$$G(x, y, z) \text{ is } G\left( \frac{x_1 + x_2 + x_3}{3}, \frac{y_1 + y_2 + y_3}{3}, \frac{z_1 + z_2 + z_3}{3} \right).$$

Hence, the centroid

7. The projection of the line joining points  $P(x_1, y_1, z_1)$  and  $Q(x_2, y_2, z_2)$  to the line with direction

$$\text{cosines, } l, m \text{ and } n \text{ is } |(x_2 - x_1)l + (y_2 - y_1)m + (z_2 - z_1)n|.$$

## Top Concepts

1. The angles  $\alpha$ ,  $\beta$  and  $\gamma$  which a directed line  $L$ , through the origin, makes with the  $x$ ,  $y$  and  $z$  axes, respectively, are called direction angles.

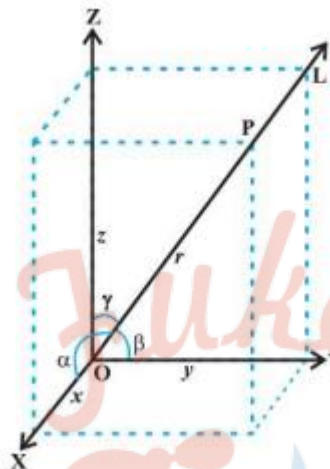

If the direction of line  $L$  is reversed, then the direction angles will  $\pi - \alpha$ ,  $\pi - \beta$  and  $\pi - \gamma$ .

2. If a directed line  $L$  passes through the origin and makes angles  $\alpha$ ,  $\beta$  and  $\gamma$  with the  $x$ ,  $y$  and  $z$  axes respectively, then

$\lambda = \cos \alpha$ ,  $m = \cos \beta$  and  $n = \cos \gamma$  are called direction cosines of line  $L$ .

3. For a given line to have a unique set of direction cosines, a directed line is used.
4. The direction cosines of the directed line which does not pass through the origin can be obtained by drawing a line parallel to it and passing through the origin.

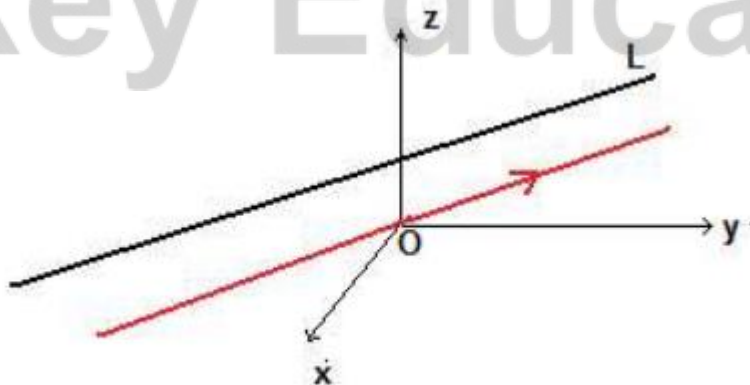

5. Any three numbers which are proportional to the direction cosines of the line are called direction ratios. If  $\lambda$ ,  $m$  and  $n$  are the direction cosines and  $a$ ,  $b$  and  $c$  are the direction ratios

of a line, then  $\lambda = ka$ ,  $m = kb$  and  $n = kc$ , where  $k$  is any non-zero real number.

6. For any line, there are an infinite number of direction ratios.

7. Direction ratios of the line joining  $P(x_1, y_1, z_1)$  and  $Q(x_2, y_2, z_2)$  may be taken as

$$x_2 - x_1, y_2 - y_1, z_2 - z_1 \text{ OR } x_1 - x_2, y_1 - y_2, z_1 - z_2$$

8. Direction cosines of the x-axis are  $\cos 0, \cos 90, \cos 90$ , i.e.,  $1, 0, 0$ .

Similarly, the direction cosines of the y-axis are  $0, 1, 0$  and the z-axis are  $0, 0, 1$ , respectively.

9. A line is uniquely determined if

1. It passes through a given point and has given direction ratios

OR

2. It passes through two given points.

10. Two lines with direction ratios  $a_1, a_2, a_3$  and  $b_1, b_2, b_3$ , respectively, are perpendicular if

$$a_1b_1 + a_2b_2 + a_3b_3 = 0$$

11. Two lines with direction ratios  $a_1, a_2, a_3$  and  $b_1, b_2, b_3$ , respectively, are parallel if

$$\frac{a_1}{b_1} = \frac{a_2}{b_2} = \frac{a_3}{b_3}$$

12. The lines which are neither intersecting nor parallel are called as skew lines. Skew lines are non-coplanar, i.e., they do not belong to the same 2D plane.

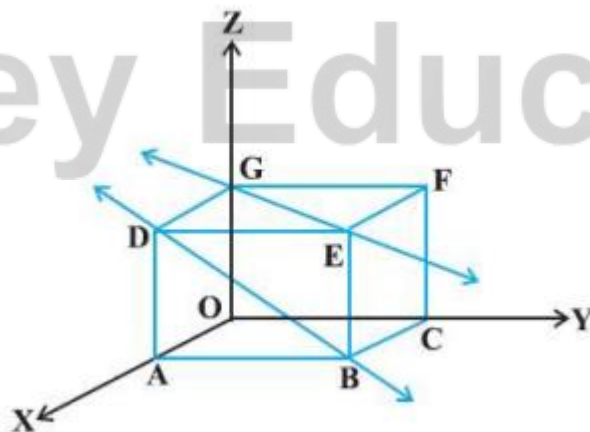

GE and DB are skew lines.

13. The **angle between skew lines** is the angle between two intersecting lines drawn from any point (preferably through the origin) parallel to each of the skew lines.

14. If two lines in space are intersecting, then the shortest distance between them is zero.
15. If two lines in space are parallel, then the shortest distance between them is the perpendicular distance.

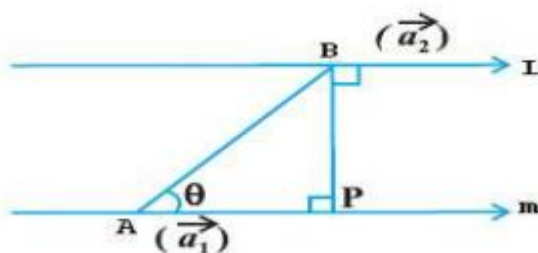

16. The normal vector, often simply called the 'normal' to a surface, is a vector perpendicular to a surface.

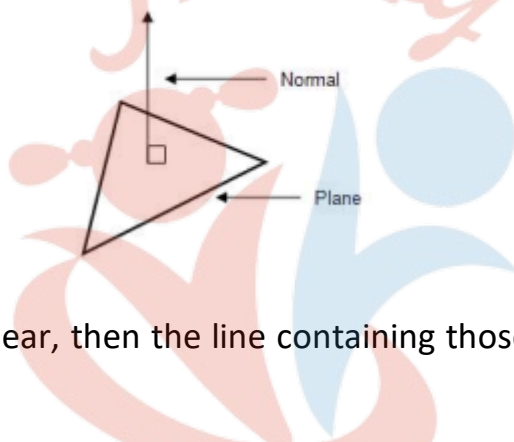

17. If the three points are collinear, then the line containing those three points can be part of many planes.

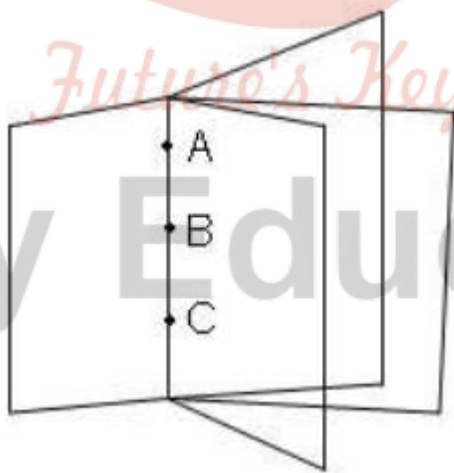

18. The angle between two planes is defined as the angle between their normals.
19. If the planes  $A_1x + B_1y + C_1z + D_1 = 0$  and  $A_2x + B_2y + C_2z + D_2 = 0$  are perpendicular to each other, then  $A_1A_2 + B_1B_2 + C_1C_2 = 0$
- If the planes  $A_1x + B_1y + C_1z + D_1 = 0$  and  $A_2x + B_2y + C_2z + D_2 = 0$  are parallel, then

$$\frac{A_1}{A_2} = \frac{B_1}{B_2} = \frac{C_1}{C_2}$$

20. The angle between a line and a plane is the complement of the angle between the line and the normal to the plane.

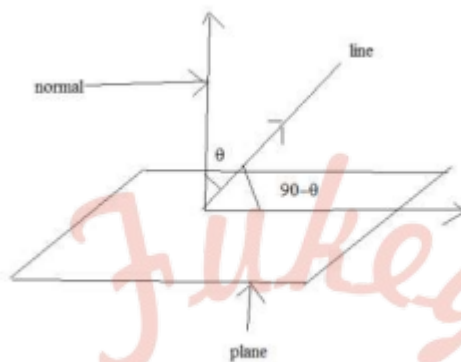

21. The distance of a point from a plane is the length of the unique line from the point to the plane which is perpendicular to the plane.

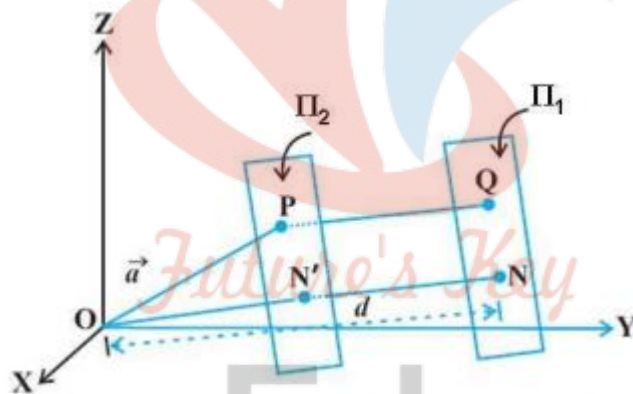

## Top Formulae

1. Direction cosines of the line L are connected by the relation  $l^2 + m^2 + n^2 = 1$ .
2. If a, b, and c are the direction ratios of a line, and l, m, and n are its direction cosines, then

$$l = \pm \frac{a}{\sqrt{a^2+b^2+c^2}}, \quad m = \pm \frac{b}{\sqrt{a^2+b^2+c^2}}, \quad n = \pm \frac{c}{\sqrt{a^2+b^2+c^2}}$$

3. The direction cosines of the line joining



$P(x_1, y_1, z_1)$  and  $Q(x_2, y_2, z_2)$  are

$$\frac{x_2 - x_1}{PQ}, \frac{y_2 - y_1}{PQ}, \frac{z_2 - z_1}{PQ}$$

where  $PQ = \sqrt{(x_2 - x_1)^2 + (y_2 - y_1)^2 + (z_2 - z_1)^2}$

4. Vector equation of a line which passes through the given point whose position vector is  $\vec{a}$  and parallel to a given vector  $\vec{b}$  is  $\vec{r} = \vec{a} + \lambda \vec{b}$

5. If coordinates of point A are  $(x_1, y_1, z_1)$  and direction ratios of the line are  $a, b, c$ , then cartesian form of equation of line is:  $\frac{x - x_1}{a} = \frac{y - y_1}{b} = \frac{z - z_1}{c}$

6. If coordinates of point A are  $(x_1, y_1, z_1)$  and direction cosines of the line are  $l, m, n$ , then Cartesian equation of line is:  $\frac{x - x_1}{l} = \frac{y - y_1}{m} = \frac{z - z_1}{n}$

7. The vector equation of a line which passes through two points whose position vectors are  $\vec{a}$  and  $\vec{b}$  is  $\vec{r} = \vec{a} + \lambda(\vec{b} - \vec{a})$

8. Cartesian equation of a line which passes through two points  $(x_1, y_1, z_1)$  and  $(x_2, y_2, z_2)$  is

$$\frac{x - x_1}{x_2 - x_1} = \frac{y - y_1}{y_2 - y_1} = \frac{z - z_1}{z_2 - z_1}$$

9. The parametric equations of the line  $\frac{x - x_1}{a} = \frac{y - y_1}{b} = \frac{z - z_1}{c}$  are

$$x = x_1 + ar, y = y_1 + br, z = z_1 + cr, \text{ where } r \in \mathbb{R}$$

10. Equation of the x-axis:  $\frac{x - 0}{1} = \frac{y - 0}{0} = \frac{z - 0}{0}$  or  $y = 0$  and  $z = 0$

11. Equation of the y-axis:  $\frac{x - 0}{0} = \frac{y - 0}{1} = \frac{z - 0}{0}$  or  $x = 0$  and  $z = 0$

12. Equation of the z-axis:  $\frac{x - 0}{0} = \frac{y - 0}{0} = \frac{z - 0}{1}$  or  $x = 0$  and  $y = 0$

13. Conversion of a Cartesian form of an equation of a line to a vector form:

Let the Cartesian form of an equation of line be  $\frac{x-x_1}{a} = \frac{y-y_1}{b} = \frac{z-z_1}{c}$ .

Hence, the vector form of the equation of the line is

$$\vec{r} = (x_1\hat{i} + y_1\hat{j} + z_1\hat{k}) + \lambda(\hat{a}i + \hat{b}j + \hat{c}k), \text{ where } \lambda \text{ is a parameter.}$$

#### 14. Conversion of a vector form of the equation of a line to the Cartesian form:

Let the Cartesian form of the equation of a line be

$$\vec{r} = \vec{a} + \lambda\vec{m}, \text{ where } \vec{a} = x_1\hat{i} + y_1\hat{j} + z_1\hat{k} \text{ and } \vec{m} = \hat{a}i + \hat{b}j + \hat{c}k$$

and  $\lambda$  is a parameter

Then the Cartesian form of the equation of the line is

$$\frac{x-x_1}{a} = \frac{y-y_1}{b} = \frac{z-z_1}{c} = \lambda.$$

#### 15. Angle $\theta$ between two lines $L_1$ and $L_2$ passing through the origin and having direction ratios $a_1, b_1, c_1$ and $a_2, b_2, c_2$ is

$$\cos \theta = \left| \frac{a_1a_2 + b_1b_2 + c_1c_2}{\sqrt{a_1^2 + b_1^2 + c_1^2} \sqrt{a_2^2 + b_2^2 + c_2^2}} \right|$$

$$\text{Or } \sin \theta = \frac{\sqrt{(a_1b_2 - a_2b_1)^2 + (b_1c_2 - b_2c_1)^2 + (c_1a_2 - c_2a_1)^2}}{\sqrt{a_1^2 + b_1^2 + c_1^2} \sqrt{a_2^2 + b_2^2 + c_2^2}}$$

#### 16. Condition of perpendicularity: If the lines are perpendicular to each other, then $a_1a_2 + b_1b_2 + c_1c_2 = 0$ .

#### 17. Condition of parallelism: If the lines are parallel, then $\frac{a_1}{a_2} = \frac{b_1}{b_2} = \frac{c_1}{c_2}$

#### 18. Equation of a line passing through a point having position vector $\vec{k}$ and perpendicular to the lines $\vec{r} = \vec{a}_1 + m\vec{b}_1$ and $\vec{r} = \vec{a}_2 + m\vec{b}_2$ is $\vec{r} = \vec{k} + m(\vec{b}_1 \times \vec{b}_2)$

#### 19. To find the intersection of two lines:

Consider the two lines:

$$\frac{x-x_1}{a_1} = \frac{y-y_1}{b_1} = \frac{z-z_1}{c_1} \text{ and } \frac{x-x_2}{a_2} = \frac{y-y_2}{b_2} = \frac{z-z_2}{c_2}$$

Step (i): The general coordinates of general points on the given two lines are

$$(a_1k + x_1, b_1k + y_1, c_1k + z_1) \text{ and } (a_2m + x_2, b_2m + y_2, c_2m + z_2)$$



Step (ii) Equate both the points

Thus, we have  $a_1k + x_1 = a_2m + x_2$ ,  $b_1k + y_1 = b_2m + y_2$ ,  $C_1k + z_1 = c_2m + z_2$

Step (iii): Solve the first two equations to get the values of  $k$  and  $m$ . Check whether the point satisfies the third equation also. If it satisfies, then the lines intersect, otherwise they do not.

Step (iv): Substitute the values of  $k$  and  $m$  in the set of three equations to get the intersection point.

20. To find the intersection of two lines in the vector form:

Let the two lines be

$$\vec{r} = (a_1\hat{i} + a_2\hat{j} + a_3\hat{k}) + k(b_1\hat{i} + b_2\hat{j} + b_3\hat{k}) \dots (1)$$

$$\vec{r} = (a_1'\hat{i} + a_2'\hat{j} + a_3'\hat{k}) + m(b_1'\hat{i} + b_2'\hat{j} + b_3'\hat{k}) \dots (2)$$

Step (i): Position vectors of arbitrary points on (1) and (2) are

$$(a_1\hat{i} + a_2\hat{j} + a_3\hat{k}) + k(b_1\hat{i} + b_2\hat{j} + b_3\hat{k})$$

$$(a_1'\hat{i} + a_2'\hat{j} + a_3'\hat{k}) + m(b_1'\hat{i} + b_2'\hat{j} + b_3'\hat{k})$$

Step (ii): Because the lines (1) and (2) intersect, they intersect each other, and their points of intersection are as follows:

$$a_1 + ka_1' = b_1 + mb_1'; a_2 + ka_2' = b_2 + mb_2'; a_3 + ka_3' = b_3 + mb_3'$$

Step (iii): Solve any two of the equations to get the values of  $k$  and  $m$ . Substitute the values of  $k$  and  $m$  in the third equation to check whether it satisfies it. If it does satisfy it, then the two lines intersect, otherwise they do not.

Step (iv): Substitute the values of  $k$  and  $m$  to get the point of intersection.

21. Perpendicular distance of a line from a point: Let  $P(u, v, w)$  be the given point.

Let  $\frac{x - x_1}{a} = \frac{y - y_1}{b} = \frac{z - z_1}{c}$  be the given line.

Let  $N$  be the foot of the perpendicular.

Then the coordinates of  $N$  are,

$$(x_1 + ak, y_1 + bk, z_1 + ck), \text{ where } k = -\frac{a(u - x_1) + b(v - y_1) + c(w - z_1)}{a^2 + b^2 + c^2}$$

Now, the distance  $PN$  can be determined using the distance formula.

22. Perpendicular distance of a line from a point when it is in the vector form:

Step (i): Let  $P(\vec{u})$  be the given point. Let  $\vec{r} = \vec{a} + k\vec{b}$  be the position vector of the line.

Step (ii): Find  $\overrightarrow{PN}$  - Position vector of  $N$  - Position vector of  $P$

Step (iii):  $\overrightarrow{PN} \cdot \vec{b} = 0$

Step (iv): Get the value of k

Step (v): Substitute the value of k in  $\vec{r} = \vec{a} + k\vec{b}$

Step (vi): Compute  $|\overrightarrow{PN}|$  to obtain the perpendicular distance.

23. Skew lines: Two lines are said to be skew lines if they are neither parallel nor intersecting.

24. Shortest distance: The shortest distance between two lines  $L_1$  and  $L_2$  is the distance PQ between the points P and Q, where the lines of shortest distance intersect the two given lines.

25. The shortest distance between two skew lines L and M having equations

$\vec{r} = \vec{a}_1 + \lambda\vec{b}_1$  and  $\vec{r} = \vec{a}_2 + \mu\vec{b}_2$  respectively, is

$$d = \frac{|(\vec{b}_1 \times \vec{b}_2) \cdot (\vec{a}_2 - \vec{a}_1)|}{|\vec{b}_1 \times \vec{b}_2|}$$

26. Condition for two given lines to intersect: If the lines  $\vec{r} = \vec{a}_1 + k\vec{b}_1$  and  $\vec{r} = \vec{a}_2 + k\vec{b}_2$  intersect, then the shortest distance between them is zero.

$$\text{Thus, } \frac{|(\vec{b}_1 \times \vec{b}_2) \cdot (\vec{a}_2 - \vec{a}_1)|}{|\vec{b}_1 \times \vec{b}_2|} = 0 \Rightarrow (\vec{b}_1 \times \vec{b}_2) \cdot (\vec{a}_2 - \vec{a}_1) = 0$$

27. The shortest distance between the lines in the Cartesian form

$$\frac{x-x_1}{a_1} = \frac{y-y_1}{b_1} = \frac{z-z_1}{c_1} \quad \text{and} \quad \frac{x-x_2}{a_2} = \frac{y-y_2}{b_2} = \frac{z-z_2}{c_2}$$

is given by

$$d = \frac{\begin{vmatrix} x_2 - x_1 & y_2 - y_1 & z_2 - z_1 \\ a_1 & b_1 & c_1 \\ a_2 & b_2 & c_2 \end{vmatrix}}{\sqrt{(b_1c_2 - b_2c_1)^2 + (c_1a_2 - c_2a_1)^2 + (a_1b_2 - a_2b_1)^2}}$$

$$\vec{r} = \vec{a}_1 + \lambda\vec{b} \quad \text{and} \quad \vec{r} = \vec{a}_2 + \mu\vec{b} \quad \text{is} \quad d = \frac{|\vec{b} \times (\vec{a}_2 - \vec{a}_1)|}{|\vec{b}|}$$

28. Distance between parallel lines

29. The equation of a plane at a distance  $d$  from the origin where  $\hat{n}$  is the unit vector normal to the plane, through the origin in vector form, is  $\vec{r} \cdot \hat{n} = d$ .
30. Equation of a plane which is at a distance of  $d$  from the origin and the direction cosines of the normal to the plane are  $l, m, n$  is  $lx + my + nz = d$ .
31. The general equation of the plane is  $ax + by + cz + d = 0$ .
32. The equation of a plane perpendicular to a given vector  $\vec{N}$  and passing through a given point  $\vec{a}$  is  $(\vec{r} - \vec{a}) \cdot \vec{N} = 0$ .
33. The equation of a plane perpendicular to a given line with direction ratios  $A, B$  and  $C$  and passing through a given point  $(x_1, y_1, z_1)$  is  $A(x - x_1) + B(y - y_1) + C(z - z_1) = 0$
34. The equation of a plane passing through three non-collinear points in the vector form is given as  $(\vec{r} - \vec{a}) \cdot [(\vec{b} - \vec{a}) \times (\vec{c} - \vec{a})] = 0$
35. Reduction of the vector form of the equation of a plane to the Cartesian equation:

Let  $\vec{r} = x\hat{i} + y\hat{j} + z\hat{k}$ ,  $\vec{a} = a_1\hat{i} + a_2\hat{j} + a_3\hat{k}$  and  $\vec{n} = n_1\hat{i} + n_2\hat{j} + n_3\hat{k}$

Then the Cartesian equation of a plane is,

$$(x - a_1)n_1 + (y - a_2)n_2 + (z - a_3)n_3 = 0$$

36. The vector equation of the plane passing through the points having position vectors  $\vec{a}, \vec{b}$  and  $\vec{c}$  is

$$\vec{r} = (1 - m - n)\vec{a} + m\vec{b} + n\vec{c} \quad (\text{parametric form})$$

$$\vec{r} \cdot (\vec{a} \times \vec{b}) + \vec{r} \cdot (\vec{b} \times \vec{c}) + \vec{r} \cdot (\vec{c} \times \vec{a}) = \vec{a} \cdot (\vec{b} \times \vec{c}) \quad (\text{non-parametric form})$$

37. The equation of a plane passing through three non-collinear points  $(x_1, y_1, z_1)$ ,  $(x_2, y_2, z_2)$  and  $(x_3, y_3, z_3)$  in the Cartesian form is

$$\begin{vmatrix} x - x_1 & y - y_1 & z - z_1 \\ x_2 - x_1 & y_2 - y_1 & z_2 - z_1 \\ x_3 - x_1 & y_3 - y_1 & z_3 - z_1 \end{vmatrix} = 0$$

38. The intercept form of the equation of a plane is  $\frac{x}{a} + \frac{y}{b} + \frac{z}{c} = 1$ , where a, b and c are the intercepts on the x, y and z-axes, respectively.

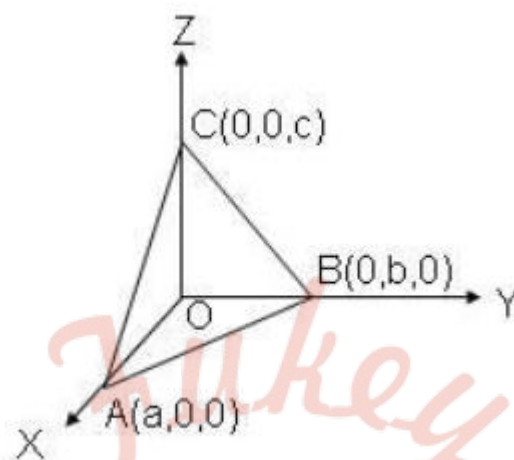

39. Any plane passing through the intersection of two planes  $\vec{r} \cdot \vec{n}_1 = d_1$  and  $\vec{r} \cdot \vec{n}_2 = d_2$  is given by  $\vec{r} \cdot (\vec{n}_1 + \lambda \vec{n}_2) = d_1 + \lambda d_2$

40. The Cartesian equation of a plane passing through the intersection of two planes

$$A_1x + B_1y + C_1z = d_1 \text{ and } A_2x + B_2y + C_2z = d_2 \text{ is}$$

$$(A_1x + B_1y + C_1z - d_1) + \lambda(A_2x + B_2y + C_2z - d_2) = 0$$

41. The equation of the planes bisecting the angles between the planes

$$a_1x + b_1y + c_1z + d_1 = 0 \text{ and } a_2x + b_2y + c_2z + d_2 = 0 \text{ is given by}$$

$$\frac{a_1x + b_1y + c_1z + d_1}{\sqrt{a_1^2 + b_1^2 + c_1^2}} = \pm \frac{a_2x + b_2y + c_2z + d_2}{\sqrt{a_2^2 + b_2^2 + c_2^2}}$$

42. The angle  $\theta$  between a line  $\frac{x-x_1}{l} = \frac{y-y_1}{m} = \frac{z-z_1}{n}$  and the plane  $ax + by + cz + d = 0$  is given by the following relation:

$$\sin \theta = \frac{al + bm + cn}{\sqrt{a^2 + b^2 + c^2} \cdot \sqrt{l^2 + m^2 + n^2}}$$

43. If a line is perpendicular to a normal to the plane, then it is parallel to the plane.

44. If a line is parallel to a normal to the plane, then it is perpendicular to the plane.

45. The line  $\vec{r} - \vec{a} + k\vec{b}$  lies in the plane  $\vec{r} \cdot \vec{n} = d$  if  $\vec{a} \cdot \vec{n} = d$  and  $\vec{b} \cdot \vec{n} = 0$

46. The line  $\frac{x-x_1}{l} = \frac{y-y_1}{m} = \frac{z-z_1}{n}$  lies in the plane  $ax + by + cz + d = 0$  if

$$ax_1 + by_1 + cz_1 + d = 0 \text{ and } al + bm + cn = 0.$$

47. The equation of a plane containing the line  $\frac{x-x_1}{l} = \frac{y-y_1}{m} = \frac{z-z_1}{n}$  is

$$a(x-x_1) + b(y-y_1) + c(z-z_1) = 0, \text{ where } al + bm + cn = 0.$$

48. The given lines  $\vec{r} = \vec{a}_1 + \lambda\vec{b}_1$  and  $\vec{r} = \vec{a}_2 + \mu\vec{b}_2$  are coplanar if and only

$$(\vec{a}_2 - \vec{a}_1) \cdot (\vec{b}_1 \times \vec{b}_2) = 0$$

49. Let  $(x_1, y_1, z_1)$  and  $(x_2, y_2, z_2)$  be the coordinates of the points M and N, respectively. Let  $a_1, b_1, c_1$  and  $a_2, b_2, c_2$  be the direction ratios of  $\vec{b}_1$  and  $\vec{b}_2$ , respectively. The given lines are coplanar if and only if,

$$\begin{vmatrix} x_2 - x_1 & y_2 - y_1 & z_2 - z_1 \\ a_1 & b_1 & c_1 \\ a_2 & b_2 & c_2 \end{vmatrix} = 0$$

50. Two lines  $\frac{x-x_1}{a_1} = \frac{y-y_1}{b_1} = \frac{z-z_1}{c_1}$  and  $\frac{x-x_2}{a_2} = \frac{y-y_2}{b_2} = \frac{z-z_2}{c_2}$  are coplanar if

$$\begin{vmatrix} x_2 - x_1 & y_2 - y_1 & z_2 - z_1 \\ a_1 & b_1 & c_1 \\ a_2 & b_2 & c_2 \end{vmatrix} = 0$$

51. The equation of the plane containing the lines

$$\frac{x-x_1}{a_1} = \frac{y-y_1}{b_1} = \frac{z-z_1}{c_1} \text{ and } \frac{x-x_2}{a_2} = \frac{y-y_2}{b_2} = \frac{z-z_2}{c_2} \text{ is}$$

$$\begin{vmatrix} x-x_1 & y-y_1 & z-z_1 \\ a_1 & b_1 & c_1 \\ a_2 & b_2 & c_2 \end{vmatrix} = 0 \text{ or } \begin{vmatrix} x-x_2 & y-y_2 & z-z_2 \\ a_1 & b_1 & c_1 \\ a_2 & b_2 & c_2 \end{vmatrix} = 0$$

52. If  $\vec{n}_1$  and  $\vec{n}_2$  are normals to the planes  $\vec{r} \cdot \vec{n}_1 = d_1$  and  $\vec{r} \cdot \vec{n}_2 = d_2$ , and  $\theta$  is the angle between the normals drawn from some common point, then

$$\cos \theta = \frac{|\vec{n}_1 \cdot \vec{n}_2|}{|\vec{n}_1| |\vec{n}_2|}$$

53. Let  $\theta$  be the angle between two planes  $A_1x + B_1y + C_1z + D_1 = 0$  and  $A_2x + B_2y + C_2z + D_2 = 0$ .

The direction ratios of the normal to the planes are  $A_1, B_1, C_1$  and  $A_2, B_2, C_2$ .

$$\cos \theta = \frac{|A_1A_2 + B_1B_2 + C_1C_2|}{\sqrt{A_1^2 + B_1^2 + C_1^2} \sqrt{A_2^2 + B_2^2 + C_2^2}}$$

54. The angle  $\theta$  between the line and the normal to the plane is given by

$$\cos\left(\frac{\pi}{2} - \theta\right) = \frac{|\vec{b} \cdot \vec{n}|}{|\vec{b}| |\vec{n}|}$$

$$\Rightarrow \sin \theta = \frac{|\vec{b} \cdot \vec{n}|}{|\vec{b}| |\vec{n}|}$$

55. The distance of point P with position vector  $\vec{a}$  from a plane the normal to the plane.

$$\vec{r} \cdot \vec{N} = d \text{ is } \frac{|\vec{a} \cdot \vec{N} - d|}{|\vec{N}|}, \text{ where } \vec{N} \text{ is}$$

56. The length of the perpendicular from the origin O to the plane is the normal to the plane.

$$\vec{r} \cdot \vec{N} = d \text{ is } \frac{|d|}{|\vec{N}|}, \text{ where } \vec{N}$$



Class : 12th Maths  
Chapter- 11 : Three dimensional Geometry

(i) two skew lines is the line segment perpendicular to both the lines  
 (ii)  $\vec{r} = \vec{a}_1 + \lambda \vec{b}_1$  and  $\vec{r} = \vec{a}_2 + \mu \vec{b}_2$  is  $\frac{(\vec{b}_1 \times \vec{b}_2) \cdot (\vec{a}_2 - \vec{a}_1)}{|\vec{b}_1 \times \vec{b}_2|}$   
 (iii)  $\frac{x-x_1}{a_1} = \frac{y-y_1}{b_1} = \frac{z-z_1}{c_1}$  and  $\frac{x-x_2}{a_2} = \frac{y-y_2}{b_2} = \frac{z-z_2}{c_2}$  is  $\begin{vmatrix} x_2-x_1 & y_2-y_1 & z_2-z_1 \\ a_1 & b_1 & c_1 \\ a_2 & b_2 & c_2 \end{vmatrix}$   
 $\frac{\vec{b} \times (\vec{a}_2 - \vec{a}_1)}{|\vec{b}|}$   
 (iv) Parallel line  $\vec{r} = \vec{a}_1 + \lambda \vec{b}$  and  $\vec{r} = \vec{a}_2 + \mu \vec{b}$  is  $\frac{\vec{b} \times (\vec{a}_2 - \vec{a}_1)}{|\vec{b}|}$

D. Cs of a line are the cosines of the angles made by the line with the positive direction of the co-ordinate axes. If  $l, m, n$  are the D. Cs of a line, then  $l^2 + m^2 + n^2 = 1$ . D. Cs of a line joining  $P(x_1, y_1, z_1)$  and  $Q(x_2, y_2, z_2)$  are  $\frac{x_2-x_1}{PQ}, \frac{y_2-y_1}{PQ}, \frac{z_2-z_1}{PQ}$ , where  $PQ = \sqrt{(x_2-x_1)^2 + (y_2-y_1)^2 + (z_2-z_1)^2}$   
 D.Rs of a line are the nos. which are proportional to the D.Cs of the line if  $l, m, n$  are the D.Cs and  $a, b, c$  are D.Rs of a line, then  $l = \frac{a}{\sqrt{a^2 + b^2 + c^2}}, m = \frac{b}{\sqrt{a^2 + b^2 + c^2}}, n = \frac{c}{\sqrt{a^2 + b^2 + c^2}}$

(i) which is at distance 'd' from origin and D.Cs of the normal to the plane as  $l, m, n$  is  $lx + my + nz = d$ .  
 (ii)  $\perp r$  to a given line with D.Rs.  $A, B, C$  and passing through  $(x_1, y_1, z_1)$  is  $A(x-x_1) + B(y-y_1) + C(z-z_1) = 0$   
 (iii) Passing through three non-collinear points  $(x_1, y_1, z_1), (x_2, y_2, z_2), (x_3, y_3, z_3)$  is  $\begin{vmatrix} x-x_1 & y-y_1 & z-z_1 \\ x_2-x_1 & y_2-y_1 & z_2-z_1 \\ x_3-x_1 & y_3-y_1 & z_3-z_1 \end{vmatrix} = 0$

(i) which contains three non-collinear points having position vectors  $\vec{a}, \vec{b}, \vec{c}$  is  $(\vec{r}-\vec{a}) \cdot [(\vec{b}-\vec{a}) \times (\vec{c}-\vec{a})] = 0$ .  
 (ii) That passes through the intersection of planes  $\vec{r} \cdot \vec{n}_1 = d_1$  &  $\vec{r} \cdot \vec{n}_2 = d_2$  is  $\vec{r} \cdot (\vec{n}_1 + \lambda \vec{n}_2) = d_1 + \lambda d_2, \lambda$  - non-zero constant.

Two lines  $\vec{r} = \vec{a}_1 + \lambda \vec{b}_1, \vec{r} = \vec{a}_2 + \mu \vec{b}_2$  are coplanar if  $(\vec{a}_2 - \vec{a}_1) \cdot (\vec{b}_1 \times \vec{b}_2) = 0$ . Equation of a plane that cuts co-ordinate axes at  $(a,0,0), (0,b,0), (0,0,c)$  is  $\frac{x}{a} + \frac{y}{b} + \frac{z}{c} = 1$ .

The distance of a point with position vector  $\vec{a}$  from the plane  $\vec{r} \cdot \vec{n} = d$  is  $|\vec{a} \cdot \vec{n} - d|$ . The distance from a point  $(x_1, y_1, z_1)$  to the plane  $Ax + By + Cz + D = 0$  is  $\frac{Ax_1 + By_1 + Cz_1 + D}{\sqrt{A^2 + B^2 + C^2}}$

Shortest distance between

Equation of a plane

Vector equation of a plane

Direction ratios and direction cosines of line

Skew lines

Angle between the two lines

These are the lines in space which are neither parallel nor intersecting. They lie in different planes. Angle between skew lines is the angle between two intersecting lines drawn from any point (origin) parallel to each of the skew lines.

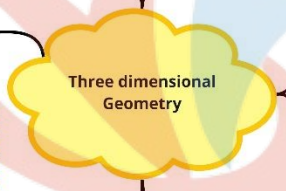

Characteristics of planes

Line of vector equations in 3D

Angle between two lines

if  $l_1, m_1, n_1, l_2, m_2, n_2$  are the D.Cs and  $a_1, b_1, c_1, a_2, b_2, c_2$  are the D.Rs of the two lines and ' $\theta$ ' is the acute angle between them, then  $\cos \theta = \frac{|l_1 a_2 + m_1 b_2 + n_1 c_2|}{\sqrt{a_1^2 + b_1^2 + c_1^2} \sqrt{a_2^2 + b_2^2 + c_2^2}}$

Vector equation of a line passing through the given point whose position vector is  $\vec{a}$  and parallel to a given vector  $\vec{b}$  is  $\vec{r} = \vec{a} + \lambda \vec{b}$

Vector equation of a line which passes through two points whose position vectors are  $\vec{a}$  and  $\vec{b}$  is  $\vec{r} = \vec{a} + \lambda (\vec{b} - \vec{a})$

Equation of a line through point  $(x_1, y_1, z_1)$  and having D.Cs  $l, m, n$  is  $\frac{x-x_1}{l} = \frac{y-y_1}{m} = \frac{z-z_1}{n}$ . Also, equation of a line that passes through two points.

If ' $\theta$ ' is the acute angle between  $\vec{r} = \vec{a}_1 + \lambda \vec{b}_1, \vec{r} = \vec{a}_2 + \mu \vec{b}_2$  then,  $\cos \theta = \frac{|\vec{b}_1 \cdot \vec{b}_2|}{|\vec{b}_1| \cdot |\vec{b}_2|}$   
 if  $\frac{x-x_1}{l_1} = \frac{y-y_1}{m_1} = \frac{z-z_1}{n_1}$  and  $\frac{x-x_2}{l_2} = \frac{y-y_2}{m_2} = \frac{z-z_2}{n_2}$  are the equations of two lines, then acute angle between them is  $\cos \theta = \frac{|l_1 \cdot l_2 + m_1 \cdot m_2 + n_1 \cdot n_2|}{\sqrt{l_1^2 + m_1^2 + n_1^2} \sqrt{l_2^2 + m_2^2 + n_2^2}}$

## Important Questions

### Multiple Choice questions-

1. Distance between two planes:

$$2x + 3y + 4z = 5 \text{ and } 4x + 6y + 8z = 12 \text{ is}$$

- (a) 2 units
- (b) 4 units
- (c) 8 units
- (d)  $\frac{1}{\sqrt{29}}$  units.

2. The planes  $2x - y + 4z = 3$  and  $5x - 2.5y + 10z = 6$  are

- (a) perpendicular
- (b) parallel
- (c) intersect along y-axis
- (d) passes through  $(0, 0, \frac{5}{4})$

3. The co-ordinates of the foot of the perpendicular drawn from the point  $(2, 5, 7)$  on the x-axis are given by:

- (a)  $(2, 0, 0)$
- (b)  $(0, 5, 0)$
- (c)  $(0, 0, 7)$
- (d)  $(0, 5, 7)$ .

4. If  $\alpha, \beta, \gamma$  are the angles that a line makes with the positive direction of x, y, z axis, respectively, then the direction-cosines of the line are:

- (a)  $\langle \sin \alpha, \sin \beta, \sin \gamma \rangle$
- (b)  $\langle \cos \alpha, \cos \beta, \cos \gamma \rangle$
- (c)  $\langle \tan \alpha, \tan \beta, \tan \gamma \rangle$
- (d)  $\langle \cos^2 \alpha, \cos^2 \beta, \cos^2 \gamma \rangle$ .

5. The distance of a point P (a, b, c) from x-axis is

(a)  $\sqrt{a^2 + c^2}$

(b)  $\sqrt{a^2 + b^2}$

(c)  $\sqrt{b^2 + c^2}$

(d)  $b^2 + c^2$ .

6. If the direction-cosines of a line are  $\langle k, k, k \rangle$ , then

(a)  $k > 0$

(b)  $0 < k < 1$

(c)  $k = 1$

(d)  $k = \frac{1}{\sqrt{3}}$  or  $-\frac{1}{\sqrt{3}}$

7. The reflection of the point  $(\alpha, \beta, \gamma)$  in the xy-plane is:

(a)  $(\alpha, \beta, 0)$

(b)  $(0, 0, \gamma)$

(c)  $(-\alpha, -\beta, \gamma)$

(d)  $(\alpha, \beta, -\gamma)$ .

8. What is the distance (in units) between two planes:

$$3x + 5y + 7z = 3 \text{ and } 9x + 15y + 21z = 9?$$

(a) 0

(b) 3

(c)  $\frac{6}{\sqrt{83}}$

(d) 6.

9. The equation of the line in vector form passing through the point  $(-1, 3, 5)$  and parallel to line  $\frac{x-3}{2} = \frac{y-4}{3}, z = 2$  is

(a)  $\vec{r} = (-\hat{i} + 3\hat{j} + 5\hat{k}) + \lambda (2\hat{i} + 3\hat{j} + \hat{k})$

(b)  $\vec{r} = (-\hat{i} + 3\hat{j} + 5\hat{k}) + \lambda (2\hat{i} + 3\hat{j})$

(c)  $\vec{r} = (2\hat{i} + 3\hat{j} - 2\hat{k}) + \lambda (-\hat{i} + 3\hat{j} + 5\hat{k})$

(d)  $\vec{r} = (2\hat{i} + 3\hat{j}) + \lambda (-\hat{i} + 3\hat{j} + 5\hat{k})$ .

10. Let the line  $\frac{x-2}{3} = \frac{y-1}{-5} = \frac{z-2}{2}$  lie in the plane  $x + 3y - \alpha z + \beta = 0$ . Then  $(\alpha, \beta)$  equals:

(a)  $(-6, -17)$

(b)  $(5, -15)$

(c)  $(-5, 5)$

(d)  $(6, -17)$ .

### Very Short Questions:

1. Find the acute angle which the line with direction-cosines  $\langle \frac{1}{\sqrt{3}}, \frac{1}{\sqrt{6}}, n \rangle$  makes with positive direction of z-axis. (C.B.S.E. Sample Paper 2018-19)

2. Find the direction-cosines of the line.

$$\frac{x-1}{2} = -y = \frac{z+1}{2} \text{ (C.B.S.E. Sample Paper 2018-19)}$$

3. If  $\alpha, \beta, \gamma$  are direction-angles of a line, prove that  $\cos 2\alpha + \cos 2\beta + \cos 2\gamma + 1 = 0$ . (N.C.E.R.T.)

4. Find the length of the intercept, cut off by the plane  $2x + y - z = 5$  on the x-axis. (C.B.S.E. Outside Delhi 2019)

5. Find the length of the perpendicular drawn from the point  $P(3, -4, 5)$  on the z-axis.

6. Find the vector equation of a plane, which is at a distance of 5 units from the origin and whose normal vector is  $2\hat{i} - \hat{j} + 2\hat{k}$

7. If a line makes angles  $90^\circ, 135^\circ, 45^\circ$  with the x, y and z-axes respectively, find its direction cosines.

8. Find the co-ordinates of the point where the line through the points A  $(3, 4, 1)$  and B  $(5, 1, 6)$  crosses the xy-plane.

9. Find the vector equation of the line which passes through the point  $(3, 4, 5)$  and is parallel to the vector  $2\hat{i} + 2\hat{j} - 3\hat{k}$

### Short Questions:



1. Find the acute angle between the lines whose direction-ratios are:  
 $\langle 1, 1, 2 \rangle$  and  $\langle -3, -4, 1 \rangle$ .

2. Find the angle between the following pair of lines:

and

$$\frac{-x+2}{-2} = \frac{y-1}{7} = \frac{z+3}{-3} \text{ and } \frac{x+2}{-1} = \frac{2y-8}{4} = \frac{z-5}{4}$$

and check whether the lines are parallel or perpendicular. (C.B.S.E. 2011)

3. Find the vector equation of the line joining  $(1, 2, 3)$  and  $(-3, 4, 3)$  and show that it is perpendicular to the z-axis. (C.B.S.E. Sample Paper 2018-19)

4. Find the vector equation of the plane, which is  $\frac{6}{\sqrt{29}}$  at a distance of

units from the origin and its normal vector from the origin is  $2\hat{i} - 3\hat{j} + 4\hat{k}$ . Also, find its cartesian form. (N.C.E.R.T.)

5. Find the direction-cosines of the unit vector perpendicular to the plane  $\vec{r} \cdot (6\hat{i} - 3\hat{j} - 2\hat{k}) + 1 = 0$  through the origin. (N.C.E.R.T.)

6. Find the acute angle between the lines

$$\frac{x-4}{3} = \frac{y+3}{4} = \frac{z+1}{5} \text{ and } \frac{x-1}{4} = \frac{y+1}{-3} = \frac{z+10}{5}$$

7. Find the angle between the line:

$\vec{r} = (\hat{i} - \hat{j} + \hat{k}) + \lambda(2\hat{i} - \hat{j} + 3\hat{k})$  and the plane  $\vec{r} \cdot (2\hat{i} + \hat{j} - \hat{k}) = 4$  Also, find whether the line is parallel to the plane or not.

8. Find the value of ' $\lambda$ ', so that the lines:

$\frac{1-x}{3} = \frac{7y-14}{\lambda} = \frac{z-3}{2}$  and  $\frac{7-7x}{3\lambda} = \frac{y-5}{1} = \frac{6-z}{5}$  are at right angles. Also, find whether the lines are intersecting or not

### Long Questions:

1. Find the shortest distance between the lines:  $\vec{r} = (4\hat{i} - \hat{j}) + \lambda(\hat{i} + 2\hat{j} - 3\hat{k})$  and  $\vec{r} = (\hat{i} - \hat{j} + 2\hat{k}) + \mu(2\hat{i} + 4\hat{j} - 5\hat{k})$  (C.B.S.E. 2018)
2. A line makes angles  $\alpha, \beta, \gamma, \delta$  with the four diagonals of a cube, prove that:

$$\cos^2 \alpha + \cos^2 \beta + \cos^2 \gamma + \cos^2 \delta = \frac{4}{3}. \text{ (N.C.E.R.T.)}$$

3. Find the equation of the plane through the line  $\frac{x-1}{3} = \frac{y-4}{2} = \frac{z-4}{-2}$  and parallel to the line:

$$\frac{x+1}{2} = \frac{1-y}{4} = \frac{z+2}{1}$$

Hence, find the shortest distance between the lines. (C.B.S.E. Sample Paper 2018-19)

4. Find the Vector and Cartesian equations of the plane passing through the points (2, 2, -1), (3,4,2) and (7,0,6). Also, find the vector equation of a plane passing through (4,3,1) and parallel to the plane obtained above. (C.B.S.E. 2019)

### Case Study Questions:

1. Suppose the floor of a hotel is made up of mirror polished Kota stone. Also, there is a large crystal chandelier attached at the ceiling of the hotel. Consider the floor of the hotel as a plane having equation  $x - 2y + 2z = 3$  and crystal chandelier at the point (3, -2, 1).



Based on the above information, answer the following questions.

- (i) The d.r.'s of the perpendicular from the point (3, -2, 1) to the plane  $x - 2y + 2z = 3$ , is:



- a.  $\langle 1, 2, 2 \rangle$
- b.  $\langle 1, -2, 2 \rangle$
- c.  $\langle 2, 1, 2 \rangle$
- d.  $\langle 2, -1, 2 \rangle$

(ii) The length of the perpendicular from the point  $(3, -2, 1)$  to the plane  $x - 2y + 2z = 3$ , is:

- a.  $\frac{2}{3}$  units
- b. 3 units
- c. 2 units
- d. None of these

(iii) The equation of the perpendicular from the point  $(3, -2, 1)$  to the plane  $x - 2y + 2z = 3$ , is:

- a.  $\frac{x-3}{1} = \frac{y+2}{-2} = \frac{z-1}{2}$
- b.  $\frac{x-3}{1} = \frac{y+2}{-2} = \frac{z-1}{2}$
- c.  $\frac{x+3}{1} = \frac{y+2}{-2} = \frac{z-1}{2}$
- d. None of these

(iv) The equation of plane parallel to the plane  $x - 2y + 2z = 3$ , which is at a unit distance from the point  $(3, -2, 1)$  is:

- a.  $x - 2y + 2z = 0$
- b.  $x - 2y + 2z = 6$
- c.  $x - 2y + 2z = 12$
- d. Both (b) and (c)

(v) The image of the point  $(3, -2, 1)$  in the given plane is:

- a.  $\left(\frac{5}{3}, \frac{2}{3}, \frac{-5}{3}\right)$
- b.  $\left(\frac{-5}{3}, \frac{-2}{3}, \frac{5}{3}\right)$
- c.  $\left(\frac{-5}{3}, \frac{2}{3}, \frac{5}{3}\right)$
- d. None of these

2. Consider the following diagram, where the forces in the cable are given.

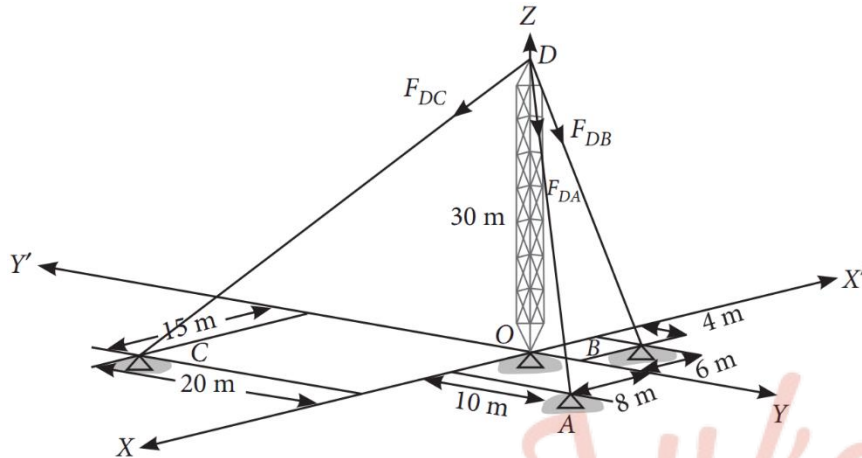

Based on the above information, answer the following questions.

i. The equation of line along the cable AD is:

a.  $\frac{x}{5} = \frac{y}{4} = \frac{z-30}{15}$

b.  $\frac{x}{4} = \frac{y}{5} = \frac{z-30}{15}$

c.  $\frac{x}{5} = \frac{y}{4} = \frac{30-z}{15}$

d.  $\frac{x}{4} = \frac{y}{5} = \frac{30-z}{15}$

ii. The length of cable DC is:

a.  $4\sqrt{61}$  m

b.  $5\sqrt{61}$  m

c.  $6\sqrt{61}$  m

d.  $7\sqrt{61}$  m

iii. The vector DB is:

a.  $-6\hat{i} + 4\hat{j} - 30\hat{k}$

b.  $6\hat{i} - 4\hat{j} + 30\hat{k}$

c.  $6\hat{i} + 4\hat{j} + 30\hat{k}$

d. None of these

iv. The sum of vectors along the cables is:

a.  $17\hat{i} + 6\hat{j} + 90\hat{k}$

b.  $17\hat{i} - 6\hat{j} - 90\hat{k}$

c.  $17\hat{i} + 6\hat{j} - 90\hat{k}$

d. None of these

v. The sum of distances of points A, B and C from the origin, i.e., OA + OB + OC is:

a.  $\sqrt{164} + \sqrt{52} + \sqrt{625}$

b.  $\sqrt{52} + \sqrt{625} + \sqrt{48}$

c.  $\sqrt{164} + \sqrt{625} + \sqrt{49}$

d. None of these

### Answer Key-

#### Multiple Choice questions-

1. Answer: (d)  $\frac{1}{\sqrt{29}}$  units.

2. Answer: (b) parallel

3. Answer: (a) (2, 0, 0)

4. Answer: (b)  $\langle \cos \alpha, \cos \beta, \cos \gamma \rangle$

5. Answer: (c)  $\sqrt{b^2 + c^2}$

6. Answer: (c)  $k = 1$

7. Answer: (d)  $(\alpha, \beta, -\gamma)$ .

8. Answer: (a) 0
9. Answer: (b)  $\vec{r} = (-\hat{i} + 3\hat{j} + 5\hat{k}) + \lambda (2\hat{i} + 3\hat{j})$
10. Answer: (a) (-6, -17)

### Very Short Answer:

1. Solution:

$$l^2 + m^2 + n^2 = 1$$

$$\left(\frac{1}{\sqrt{3}}\right)^2 + \left(\frac{1}{\sqrt{6}}\right)^2 + n^2 = 1$$

$$\Rightarrow \frac{1}{3} + \frac{1}{6} + n^2 = 1$$

$$n^2 = 1 - \frac{1}{2}$$

$$n^2 = \frac{1}{2}$$

$$n = \frac{1}{\sqrt{2}}$$

$$\text{Thus, } \cos \alpha = \frac{1}{\sqrt{2}}$$

$$\text{Hence, } \alpha = 45^\circ \text{ or } \frac{\pi}{4}$$

2. Solution:

$$\text{The given line is } \frac{x-1}{2} = \frac{y}{-1} = \frac{z+1}{2}$$

Its direction-ratios are  $\langle 2, -1, 2 \rangle$ .

Hence, its direction- cosine are:

$$\left\langle \frac{2}{\sqrt{4+1+4}}, \frac{-1}{\sqrt{4+1+4}}, \frac{2}{\sqrt{4+1+4}} \right\rangle$$

$$\text{i.e. } \left\langle \frac{2}{3}, \frac{-1}{3}, \frac{2}{3} \right\rangle \text{ or } \left\langle \frac{2}{3}, \frac{1}{3}, \frac{-2}{3} \right\rangle.$$

3. Solution:

Since  $\alpha, \beta, \gamma$  are direction-angles of a line,

$$\therefore \cos^2 \alpha + \cos^2 \beta + \cos^2 \gamma = 1$$

$$\left\langle \frac{2}{\sqrt{4+1+4}}, \frac{-1}{\sqrt{4+1+4}}, \frac{2}{\sqrt{4+1+4}} \right\rangle$$

$$\text{i.e. } \left\langle \frac{2}{3}, \frac{-1}{3}, \frac{2}{3} \right\rangle \text{ or } \left\langle \frac{2}{3}, \frac{1}{3}, \frac{-2}{3} \right\rangle.$$

$$\Rightarrow 1 + \cos^2 \alpha + 1 + \cos^2 \beta + 1 + \cos^2 \gamma = 2$$

$$\Rightarrow \cos^2 \alpha + \cos^2 \beta + \cos^2 \gamma + 1 = 0, \text{ which is true.}$$

4. Solution:

The given plane is  $2x + y - z = 5$

$$\Rightarrow \frac{x}{5/2} + \frac{y}{5} + \frac{z}{-5} = 1$$

Its intercepts are  $\frac{x}{5/2}, 5$  and  $-5$ .

Hence, the length of the intercept on the x-axis is  $\frac{x}{5/2}$

Solution:

Length of the perpendicular from P (3, -4, 5) on the z-axis

$$= \sqrt{(3)^2 + (-4)^2}$$

$$= \sqrt{9 + 16} = \sqrt{25} = 5 \text{ units.}$$

5. Solution:

$$\text{Let } \vec{n} = 2\hat{i} - \hat{j} + 2\hat{k}$$

$$\text{Then, } |\vec{n}| = \sqrt{4+1+4} = \sqrt{9} = 3.$$

$$\text{Now, } \hat{n} = \frac{\vec{n}}{|\vec{n}|} = \frac{2\hat{i} - \hat{j} + 2\hat{k}}{3}.$$

Hence, the reqd. equation of the plane is:

$$\vec{r} \cdot \left( \frac{2}{3}\hat{i} - \frac{1}{3}\hat{j} + \frac{2}{3}\hat{k} \right) = 5$$

$$\Rightarrow \vec{r} \cdot (2\hat{i} - \hat{j} + 2\hat{k}) = 15.$$

6. Solution:

Direction cosines of the line are:

$$\langle \cos 90^\circ, \cos 135^\circ, \cos 45^\circ \rangle$$

$$\langle 0, -\frac{1}{\sqrt{2}}, \frac{1}{\sqrt{2}} \rangle$$

7. Solution:

The equations of the line through A (3,4,1) and B (5,1,6) are:

$$\frac{x-3}{5-3} = \frac{y-4}{1-4} = \frac{z-1}{6-1}$$

$$\Rightarrow \frac{x-3}{2} = \frac{y-4}{-3} = \frac{z-1}{5} \quad \dots(1)$$

Any point on (1) is  $(3 + 2k, 4 - 3k, 1 + 5k) \dots (2)$

This lies on xy-plane ( $z = 0$ ).

$$\therefore 1 + 5k = 0 \Rightarrow k = -\frac{1}{5}$$

Putting in (2),  $\left[ 3 - \frac{2}{5}, 4 + \frac{3}{5}, 1 - 1 \right)$

$$\text{i.e. } \left( \frac{13}{5}, \frac{23}{5}, 0 \right)$$

which are the reqd. co-ordinates of the point.

8. Solution:

The vector equation of the line is  $\vec{r} = \vec{a} + \lambda\vec{m}$

$$\text{i.e., } \vec{r} = (3\hat{i} + 4\hat{j} + 5\hat{k}) + \lambda(2\hat{i} + 2\hat{j} - 3\hat{k})$$



## Short Answer:

1. Solution:

$$\begin{aligned}\cos \theta &= \frac{|a_1 a_2 + b_1 b_2 + c_1 c_2|}{\sqrt{a_1^2 + b_1^2 + c_1^2} \sqrt{a_2^2 + b_2^2 + c_2^2}} \\ &= \frac{|(1)(-3) + (1)(-4) + (2)(1)|}{\sqrt{1+1+4} \sqrt{9+16+1}} \\ &= \frac{|-3-4+2|}{\sqrt{6}\sqrt{26}} = \frac{5}{\sqrt{156}}.\end{aligned}$$

$$\text{Hence, } \theta = \cos^{-1} \left( \frac{5}{\sqrt{156}} \right).$$

2. Solution:

The given lines can be rewritten as:

$$\frac{-x+2}{-2} = \frac{y-1}{7} = \frac{z+3}{-3} \dots\dots\dots (1)$$

$$\frac{x+2}{-1} = \frac{2y-8}{4} = \frac{z-5}{4} \dots\dots\dots (2)$$

Here  $\langle 2, 7, -3 \rangle$  and  $\langle -1, 2, 4 \rangle$  are direction-ratios of lines (1) and (2) respectively.

$$\begin{aligned}\therefore \cos \theta &= \frac{(2)(-1) + (7)(2) + (-3)(4)}{\sqrt{4+49+9} \sqrt{1+4+16}} \\ &= \frac{-2+14-12}{\sqrt{62} \sqrt{21}} = 0\end{aligned}$$

$$\Rightarrow \theta = \frac{\pi}{2}.$$

Hence, the given lines are perpendicular.

3. Solution:

Vector equation of the line passing through

$$(1.2.3) \text{ and } (-3, 4, 3) \text{ is } \vec{r} = \vec{a} + \lambda(\vec{b} - \vec{a})$$

$$\text{where } \vec{a} = \hat{i} + 2\hat{j} + 3\hat{k} \text{ and } \vec{b} = -3\hat{i} + 4\hat{j} + 3\hat{k}$$

$$\Rightarrow \vec{r} = (\hat{i} + 2\hat{j} + 3\hat{k}) + \lambda(-4\hat{i} + 2\hat{j}) \dots(1)$$

$$\text{Equation of z-axis is } \vec{r} = \mu\hat{k} \dots(2)$$

$$\text{Since } (-4\hat{i} + 2\hat{j}) \cdot \hat{k} = 0 = 0,$$

$\therefore$  Line (1) is perpendicular to z-axis.

4. Solution:

$$\text{Let } \vec{n} = 2\hat{i} - 3\hat{j} + 4\hat{k}.$$

$$\text{Then } |\vec{n}| = \sqrt{4 + 9 + 16} = \sqrt{29}.$$

$$\text{Now } \hat{n} = \frac{\vec{n}}{|\vec{n}|} = \frac{2\hat{i} - 3\hat{j} + 4\hat{k}}{\sqrt{29}}.$$

Hence, the reqd. equation of the plane is :

$$\vec{r} \cdot \left( \frac{2}{\sqrt{29}}\hat{i} - \frac{3}{\sqrt{29}}\hat{j} + \frac{4}{\sqrt{29}}\hat{k} \right) = \frac{6}{\sqrt{29}},$$

In Cartesian Form :

$$(x\hat{i} + y\hat{j} + z\hat{k}) \cdot \left( \frac{2}{\sqrt{29}}\hat{i} - \frac{3}{\sqrt{29}}\hat{j} + \frac{4}{\sqrt{29}}\hat{k} \right) = \frac{6}{\sqrt{29}}$$

$$\Rightarrow (x) \left( \frac{2}{\sqrt{29}} \right) + y \left( \frac{-3}{\sqrt{29}} \right) + z \left( \frac{4}{\sqrt{29}} \right) = \frac{6}{\sqrt{29}}$$

$$\Rightarrow 2x - 3y + 4z = 6.$$

5. Solution:

The given plane is  $\vec{r} \cdot (6\hat{i} - 3\hat{j} - 2\hat{k}) + 1 = 0$

$$\vec{r} \cdot (6\hat{i} - 3\hat{j} - 2\hat{k}) = -1 \dots\dots\dots (1)$$

$$\begin{aligned} \text{Now } | -6\hat{i} + 3\hat{j} + 2\hat{k} | &= \sqrt{36 + 9 + 4} \\ &= \sqrt{49} = 7 \end{aligned}$$

Dividing (1) by 7,

$$\vec{r} \cdot \left( -\frac{6}{7}\hat{i} + \frac{3}{7}\hat{j} + \frac{2}{7}\hat{k} \right) = -\frac{1}{7}$$

which is the equation of the plane in the form  $\vec{r} \cdot \hat{n} = p$

$$\text{Thus, } \hat{n} = -\frac{6}{7}\hat{i} + \frac{3}{7}\hat{j} + \frac{2}{7}\hat{k}$$

which is the unit vector perpendicular to the plane through the origin.

Hence, the direction-cosines of  $\hat{n}$  are  $\left\langle -\frac{6}{7}, \frac{3}{7}, \frac{2}{7} \right\rangle$

6. Solution:

Vector in the direction of first line

$$\frac{x-4}{3} = \frac{y+3}{4} = \frac{z+1}{5}, \quad \text{Future's Key}$$

$$\vec{b} = (3\hat{i} + 4\hat{j} + 5\hat{k})$$

Vector in the direction of second line

$$\frac{x-1}{4} = \frac{y+1}{-3} = \frac{z+10}{5}$$

$$\vec{d} = 4\hat{i} - 3\hat{j} + 5\hat{k}$$

$\therefore \theta$ , the angle between two given lines is given by:

$$\begin{aligned}\cos \theta &= \frac{\vec{b} \cdot \vec{d}}{|\vec{b}| |\vec{d}|} \\ &= \frac{(3\hat{i} + 4\hat{j} + 5\hat{k}) \cdot (4\hat{i} - 3\hat{j} + 5\hat{k})}{|3\hat{i} + 4\hat{j} + 5\hat{k}| |4\hat{i} - 3\hat{j} + 5\hat{k}|} \\ &= \frac{(3)(4) + (4)(-3) + (5)(5)}{\sqrt{9+16+25} \sqrt{16+9+25}} \\ &= \frac{12-12+25}{\sqrt{50}\sqrt{50}} = \frac{25}{50} = \frac{1}{2}.\end{aligned}$$

$$\text{Hence, } \theta = \frac{\pi}{3}$$

7. Solution:

The given line is:

$$\vec{r} = (\hat{i} - \hat{j} + \hat{k}) + \lambda(2\hat{i} - \hat{j} + 3\hat{k})$$

and the given plane is  $\vec{r} \cdot (2\hat{i} + \hat{j} - \hat{k}) = 4$ .

Now the line is parallel to  $2\hat{i} - \hat{j} + 3\hat{k}$  and normal to the plane  $2\hat{i} + \hat{j} - \hat{k}$

If ' $\theta$ ' is the angle between the line and the plane,

then  $(\frac{\pi}{2} - \theta)$  is the angle between the line and normal to the plane.

Then

$$\cos \left( \frac{\pi}{2} - \theta \right) = \frac{(2\hat{i} - \hat{j} + 3\hat{k}) \cdot (2\hat{i} + \hat{j} - \hat{k})}{\sqrt{4+1+9} \sqrt{4+1+1}}$$

$$\Rightarrow \sin \theta = \frac{4-1-3}{\sqrt{14}\sqrt{6}} = 0$$

$$\Rightarrow \theta = 0^\circ.$$

Hence, the line is parallel to the plane.

8. Solution:

(i) The given lines are

$$\frac{1-x}{3} = \frac{7y-14}{\lambda} = \frac{z-3}{2} \dots\dots\dots(1)$$

$$\text{and } \frac{7-7x}{3\lambda} = \frac{y-5}{1} = \frac{6-z}{5} \dots\dots\dots(2)$$

These are perpendicular if:

$$(-3)\left(-\frac{3\lambda}{7}\right) + \left(\frac{\lambda}{7}\right)(1) + 2(-5) = 0$$

$$\text{if } \frac{9\lambda}{7} + \frac{\lambda}{7} - 10 = 0 \text{ if } \frac{10\lambda}{7} = 10.$$

Hence  $\lambda = 1$ .

(ii) The direction cosines of line (1) are  $\langle -3, 1, 2 \rangle$

The direction cosines of line (2) are  $\langle -3, 1, -5 \rangle$

Clearly, the lines are intersecting.

### Long Answer:

1. Solution:

Comparing given equations with:

**Fukey Education**

$\vec{r} = \vec{a}_1 + \lambda \vec{b}_1$  and  $\vec{r} = \vec{a}_2 + \mu \vec{b}_2$ , we have:

$$\vec{b}_1 = \vec{i} + 2\vec{j} - 3\vec{k}, \vec{b}_2 = 2\vec{i} + 4\vec{j} - 5\vec{k}.$$

and  $\vec{a}_1 = (4\vec{i} - \vec{j}), \vec{a}_2 = \vec{i} - \vec{j} + 2\vec{k}.$

$$\text{Now, } \vec{b}_1 \times \vec{b}_2 = \begin{vmatrix} \hat{i} & \hat{j} & \hat{k} \\ 1 & 2 & -3 \\ 2 & 4 & -5 \end{vmatrix}$$

$$= \hat{i}(-10+12) - \hat{j}(-5+6) + \hat{k}(4-4) = 2\hat{i} - \hat{j}.$$

$$\therefore \left| \vec{b}_1 \times \vec{b}_2 \right| = \sqrt{(2)^2 + (-1)^2 + 0^2} \\ = \sqrt{4+1+0} = \sqrt{5}.$$

Also,  $\vec{a}_2 - \vec{a}_1 = (\vec{i} - \vec{j} + 2\vec{k}) - (4\vec{i} - \vec{j}) \\ = -3\vec{i} + 2\vec{k}.$

$$\therefore d, \text{ the S.D.} = \left| \frac{(\vec{b}_1 \times \vec{b}_2) \cdot (\vec{a}_2 - \vec{a}_1)}{|\vec{b}_1 \times \vec{b}_2|} \right| \\ = \left| \frac{(2\hat{i} - \hat{j}) \cdot (-3\hat{i} + 2\hat{k})}{\sqrt{5}} \right|$$

$$= \left| \frac{(2)(-3) + (-1)(0) + (0)(2)}{\sqrt{5}} \right|$$

$$= \left| \frac{-6-0+0}{\sqrt{5}} \right| = \frac{6}{\sqrt{5}} = \frac{6\sqrt{5}}{5} \text{ units.}$$

2. Solution:

Let O be the origin and OA, OB, OC (each = a) be the axes.



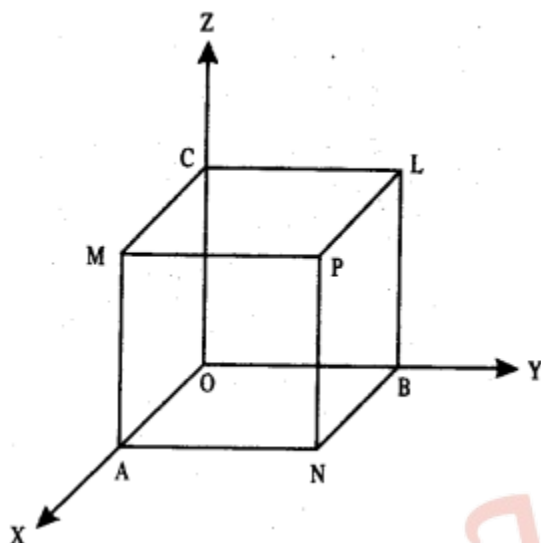

Thus the co-ordinates of the points are :

$O (0,0,0)$ ,  $A (a, 0,0)$ ,  $B (0, a, 0)$ ,  $C (0,0, a)$ ,

$P (a, a, a)$ ,  $L (0, a, a)$ ,  $M (a, 0, a)$ ,  $N (a, a, 0)$ .

Here  $OP$ ,  $AL$ ,  $BM$  and  $CN$  are four diagonals.

Let  $\langle l, m, n \rangle$  be the direction-cosines of the given line.

Now direction-ratios of  $OP$  are:

$\langle a-0, a-0, a-0 \rangle$  i.e.  $\langle a, a, a \rangle$

i.e.  $\langle 1, 1, 1 \rangle$ ,

direction-ratios of  $AL$  are:

$\langle 0-a, a-0, a-0 \rangle$  i.e.  $\langle -a, a, a \rangle$

i.e.  $\langle -1, 1, 1 \rangle$ ,

direction-ratios of  $BM$  are:

$\langle a-0, 0-a, a-0 \rangle$

i.e.  $\langle a, -a, a \rangle$  i.e.  $\langle 1, -1, 1 \rangle$

and direction-ratios of  $CN$  are:

$\langle a-0, a-0, 0-a \rangle$  i.e.  $\langle a, a, -a \rangle$

i.e.  $\langle 1, 1, -1 \rangle$ .

Thus the direction-cosines of OP are:

$$\left\langle \frac{1}{\sqrt{3}}, \frac{1}{\sqrt{3}}, \frac{1}{\sqrt{3}} \right\rangle$$

the direction-cosines of AL are:

$$\left\langle -\frac{1}{\sqrt{3}}, \frac{1}{\sqrt{3}}, \frac{1}{\sqrt{3}} \right\rangle$$

the direction-cosines of BM are:

$$\left\langle \frac{1}{\sqrt{3}}, -\frac{1}{\sqrt{3}}, \frac{1}{\sqrt{3}} \right\rangle$$

and the direction-cosines of CN are:

$$\left\langle \frac{1}{\sqrt{3}}, \frac{1}{\sqrt{3}}, -\frac{1}{\sqrt{3}} \right\rangle$$

If the given line makes an angle 'a' with OP, then:

$$\cos \alpha = \left| l \left( \frac{1}{\sqrt{3}} \right) + m \left( \frac{1}{\sqrt{3}} \right) + n \left( \frac{1}{\sqrt{3}} \right) \right|.$$

$$\therefore \cos \alpha = \frac{|l+m+n|}{\sqrt{3}} \quad \dots(1)$$

If the given line makes an angle 'β' with AL,  
then :

$$\cos \beta = \left| l \left( -\frac{1}{\sqrt{3}} \right) + m \left( \frac{1}{\sqrt{3}} \right) + n \left( \frac{1}{\sqrt{3}} \right) \right|$$

$$\therefore \cos \beta = \frac{|-l+m+n|}{\sqrt{3}} \quad \dots(2)$$

$$\text{Similarly, } \cos \gamma = \frac{|l-m+n|}{\sqrt{3}} \quad \dots(3)$$

$$\text{and } \cos \delta = \frac{|l+m-n|}{\sqrt{3}} \quad \dots\dots\dots (4)$$

Squaring and adding (1), (2), (3) and (4), we get:

$$\begin{aligned} & \cos^2 \alpha + \cos^2 \beta + \cos^2 \gamma + \cos^2 \delta \\ &= \frac{1}{3} [(l+m+n)^2 + (-l+m+n)^2 \end{aligned}$$

$$+ (1-m+n)^2 + (1+m-n)^2]$$

$$= \frac{1}{3} [4(l^2 + m^2 + n^2)] = \frac{1}{3} [4(1)].$$

$$\text{Hence, } \cos^2 \alpha + \cos^2 \beta + \cos^2 \gamma + \cos^2 \delta = \frac{4}{3}$$

3. Solution:

The two given lines are:

$$\frac{x-1}{3} = \frac{y-4}{2} = \frac{z-4}{-2} \dots\dots\dots (1)$$

$$\text{and } \frac{x+1}{2} = \frac{1-y}{4} = \frac{z+2}{1} \dots\dots\dots (2)$$

Let  $\langle a, b, c \rangle$  be the direction-ratios of the normal to the plane containing line (1).

$\therefore$  Equation of the plane is:

$$a(x-1) + b(y-4) + c(z-4) \dots(3),$$

$$\text{where } 3a + 2b - 2c = 0 \dots(4)$$

$$[\because \text{Reqd. plane contains line (1)}] \text{ and } 2a - 4b + 1.c = 0$$

[ $\because$  line (1) a parallel to the reqd. plane] Solving (4) and (5),

$$\Rightarrow \frac{a}{-6} = \frac{b}{-7} = \frac{c}{-16}$$

$$\Rightarrow \frac{a}{6} = \frac{b}{7} = \frac{c}{16} = k, \text{ where } k \neq 0.$$

$$\therefore a = 6k, b = 7k \text{ and } c = 16k.$$

Putting in (3),

$$6k(x-1) + 7k(y-4) + 16k(z-4) = 0$$

$$= 6(x-1) + 7(y-4) + 16(z-4) = 0$$

[ $\because k \neq 0$ ]

$$\Rightarrow 6x + 7y + 16z - 98 = 0,$$

which is the required equation of the plane.

Now, S.D. between two lines = perpendicular distance of  $(-1, 1, -2)$  from the plane

$$\begin{aligned} \text{i.e. S.D.} &= \left| \frac{6(-1) + 7(1) + 16(-2) - 98}{\sqrt{(6)^2 + (7)^2 + (16)^2}} \right| \\ &= \left| \frac{-6 + 7 - 32 - 98}{\sqrt{36 + 49 + 256}} \right| = \frac{129}{\sqrt{341}} \text{ units.} \end{aligned}$$

$$6(-1) + 7(1) + 16(-2) - 98$$

$$\sqrt{(6)^2 + (7)^2 + (16)^2}$$

$$-6 + 7 - 32 - 98 \quad \sqrt{36 + 49 + 256}$$

4. Solution:

(i) Cartesian equations

Any plane through (2, 2, -1) is:

$$a(x - 2) + b(y - 2) + c(z + 1) = 0 \dots (1)$$

Since the plane passes through the points (3, 4, 2) and (7, 0, 6),

$$\therefore a(3 - 2) + b(4 - 2) + c(2 + 1) = 0$$

$$\text{and } a(7 - 2) + b(0 - 2) + c(6 + 1) = 0$$

$$\Rightarrow a + 2b + 3c = 0 \dots (2)$$

$$\text{and } 5a - 2b + 7c = 0 \dots (3)$$

$$\text{Solving (2) and (3), } \frac{a}{14+6} = \frac{b}{15-7} = \frac{c}{-2-10}$$

$$\Rightarrow \frac{a}{20} = \frac{b}{8} = \frac{c}{-12}$$

$$\Rightarrow \frac{a}{5} = \frac{b}{2} = \frac{c}{-3} = k \text{ (say), value } k \neq 0.$$

$$\therefore a = 5k, b = 2k \text{ and } c = -3k,$$

Putting the values of a, b, c in (1), we get:

$$5k(x - 2) + 2k(y - 2) - 3k(z + 1) = 0$$

$$\Rightarrow 5(x-2) + 2(y-2) - 3(z+1) = 0 [\because k \neq 0]$$

$$\Rightarrow 5x - 10 + 2y - 4 - 3z - 3 = 0$$

$$\Rightarrow 5x + 2y - 3z - 17 = 0, \dots (4)$$

which is the reqd. Cartesian equation.

Its vector equation is  $\vec{r} \cdot (5\hat{i} + 2\hat{j} - 3\hat{k}) = 17$ .

(ii) Any plane parallel to (4) is

$$5x + 2y - 3z + \lambda - 0 \dots (5)$$

Since it passes through (4, 3, 1),

$$5(4) + 2(3) - 3(1) + \lambda = 0$$

$$\Rightarrow 20 + 6 - 3 + \lambda = 0$$

$$\Rightarrow \lambda = -23.$$

Putting in (5),  $5x + 2y - 3z - 23 = 0$ , which is the reqd. equation.

Its vector equation is  $\vec{r} \cdot (5\hat{i} + 2\hat{j} - 3\hat{k}) = 23$ .

### Case Study Answers:

#### 1. Answer :

i. (b)  $\langle 1, -2, 2 \rangle$

##### Solution:

Equation of plane is  $x - 2y + 2z = 3$

$\therefore$  D.R.'s of normal to the plane are , which is also the D.R.'s of perpendicular from the point (3, -2, 1) to the given plane.

ii. (c) 2 units

##### Solution:

Required length = Perpendicular distance from (3, -2, 1) to the plane  $x - 2y + 2z = 3$

$$= \left| \frac{3 - 2(-2) + 2(1) - 3}{\sqrt{1^2 + (-2)^2 + 2^2}} \right| = \frac{6}{3} = 2 \text{ units}$$

$$\text{iii. (b) } \frac{x-3}{1} = \frac{y+2}{-2} = \frac{z-1}{2}$$

**Solution:**

The equation of perpendicular from the point  $(x_1, y_1, z_1)$  to the plane  $ax + by + cz = d$  is given by

$$\frac{x-x_1}{a} = \frac{y-y_1}{b} = \frac{z-z_1}{c}$$

Here,  $x_1 = 3, y_1 = -2, z_1 = 1$  and  $a = 1, b = -2, c = 2$

$$\therefore \text{ Required equation is } \frac{x-3}{1} = \frac{y+2}{-2} = \frac{z-1}{2}$$

iv. (d) Both (b) and (c)

**Solution:**

The equation of the plane parallel to the plane  $x - 2y + 2z - 3 = 0$  is  $x - 2y + 2z + \lambda = 0$

Now, distance of this plane from the point  $(3, -2, 1)$  is

$$= \left| \frac{3+4+2+\lambda}{\sqrt{1^2+(-2)^2+2^2}} \right| = \left| \frac{9+\lambda}{3} \right|$$

But, this distance is given to be unity

$$\therefore |9 + \lambda| = 3$$

$$\Rightarrow \lambda + 9 = \pm 3 \Rightarrow \lambda = -6$$

Or -12

Thus, required equation of planes are

$$x - 2y + 2z - 6 = 0 \text{ or } x - 2y + 2z - 12 = 0$$

Fukey Education



$$v. (a) \left( \frac{5}{3}, \frac{2}{3}, \frac{-5}{3} \right)$$

**Solution:**

Let the coordinate of image of  $(3, -2, 1)$  be

$$Q(r + 3, -2r - 2, 2r + 1)$$

Let R be the mid-point of PQ, then coordinate of R be

$$\left( \frac{r+6}{2}, \frac{-2r-4}{2}, r + 1 \right)$$

Since, R lies on the plane  $x - 2y + 2z = 3$

$$\therefore \left( \frac{r+6}{2} \right) - 2 \left( \frac{-2r-4}{2} \right) + 2(r + 1) = 3$$

$$\Rightarrow 9r = -12 \Rightarrow r = -\frac{4}{3}$$

Thus, the coordinates of Q be  $\left( \frac{5}{3}, \frac{2}{3}, \frac{-5}{3} \right)$ .

**2. Answer :**

$$i. (d) \frac{x}{4} = \frac{y}{5} = \frac{30-z}{15}$$

**Solution:**

Clearly, the coordinates of A are  $(8, 10, 0)$  and D are  $(0, 0, 30)$

$\therefore$  Equation of AD is given by

$$\frac{x-0}{8-0} = \frac{y-0}{10-0} = \frac{30-z}{-30}$$

$$\Rightarrow \frac{x}{4} = \frac{y}{5} = \frac{30-z}{15}$$

ii. (b)  $5\sqrt{61}\text{m}$

**Solution:**

The coordinates of point C are (15, -20, 0) and D are (0, 0, 30)

∴ Length of the cable DC

$$= \sqrt{(0 - 15)^2 + (0 - 20)^2 + (30 - 0)^2}$$

$$= \sqrt{225 + 400 + 900}$$

$$= \sqrt{1525} = \sqrt{61}\text{m.}$$

iii. (a)  $-6\hat{i} + 4\hat{j} - 30\hat{k}$

**Solution:**

Since, the coordinates of point B are (-6, 4, 0) and D are (0, 0, 30), therefore vector DB is

$$(-6 - 0)\hat{i} + (4 - 0)\hat{j} + (0 - 30)\hat{k},$$

$$\text{i.e., } -6\hat{i} + 4\hat{j} - 30\hat{k}$$

iv. (b)  $17\hat{i} - 6\hat{j} - 90\hat{k}$

**Solution:**

Required sum

$$(8\hat{i} + 10\hat{j} - 30\hat{k}) + (-6\hat{i} + 4\hat{j} - 30\hat{k}) + (15\hat{i} - 20\hat{j} - 30\hat{k})$$

$$17\hat{i} - 6\hat{j} - 90\hat{k}$$

v. (a)  $\sqrt{164} + \sqrt{52} + \sqrt{625}$

**Solution:**

$$\text{Clearly, } OA = \sqrt{8^2 + 10^2} = \sqrt{164}$$

$$OB = \sqrt{6^2 + 4^2} = \sqrt{36 + 16} = \sqrt{52}$$

$$\text{And } OC = \sqrt{15^2 + 20^2} = \sqrt{225 + 400} = \sqrt{625}$$